



Model
DFC Valve Actuator
Operation, Parts and Instruction Manuals

Figure 1 Model DFC
Actuator and DF2000 Valve



Dyna-Flo DFC

Operation, Parts and Instruction Manual

Table of Contents

Actuator Specifications	3	Actuator Disassembly	7
Unpacking Actuator	4	Actuator Assembly	8
Rigging Set Up Diagram	4	Actuator Mounting Diagram	9
Bench Setting	4	Torque Chart	11
Bench Setting Diagram	5	DFC Diaphragm Plate Diagram	11
Mounting	5	Actuator Cross Section	12
Yoke Nut Tightening Diagram	6	Parts List	14
Maintenance	7	Model Builder	20



Model **DFC** Valve Actuator Operation, Parts and Instruction Manuals

!NOTICE!

These instructions are meant to be used in conjunction with the Dyna-Flo DFC/DFO Series Technical (Sales) Bulletin. If you do not have the Technical Bulletin, contact Dyna-Flo immediately, or visit www.dynaflo.com

It is the intention of this document to provide users with an accurate guide for safe installation and maintenance of Model DFC valve actuators. Revisions and updates are available at above mentioned website.

Introduction

The Model DFC series linear output spring and diaphragm actuators are used in all kinds of demanding applications. The large area of the diaphragm allows low-pressure operation, and the spring provides fail safe positioning of a control valve on loss of the pneumatic supply. Model DFC actuators are used to automate control valves in both throttling and on/off control of liquids or gases.

When combined with a Dyna-Flo Model DF2000 or 360 control valve, the DFC is part of a rugged control valve assembly, to which a wide variety of controllers and instruments can be attached.

Dyna-Flo's high level of quality specifications used in manufacturing the Model DFC and DFO series linear pneumatic actuators ensures superior performance and customer satisfaction.

General

The following instructions are to be thoroughly reviewed and understood prior to installing, operating or performing maintenance on this equipment. Work on this equipment should be done by experienced personnel. Throughout the manual, safety and caution notes appear and must be strictly followed to prevent serious injury or equipment malfunction.

Scope

This manual will provide detailed information on the complete disassembly and reassembly of the Model DFC pneumatic actuator. Refer to separate instruction manuals for the installation of positioners and all other accessories used with these actuators. Do not apply any other conditions to the actuator without first contacting your Dyna-Flo sales office.

This manual is written to be a practical and useful guide to successfully using the Dyna-Flo Model DFC for many years.

! CAUTION !

To avoid personal injury or installation damage as a result of the sudden release of process pressure or the breaking of parts, do not install the actuator assembly where service conditions could exceed the limits stated in this manual or on the equipment nameplates. Only well trained experienced technicians should perform these procedures. Be sure to use safe work practices and lockout procedures. Always be aware of the hazards of spring-loaded actuators. Be sure that they are in the failed (de-energized) position before performing any maintenance procedure. These actuators have dangerous pinch points. Never put your hands inside the valve unless you are certain that the actuator cannot move.



Model
DFC Valve Actuator
 Operation, Parts and Instruction Manuals

Table 1

Model DFC Actuator Specifications

SPECIFICATION		ACTUATOR SIZE							
		1069	2069	2105	2156	3105	3156	3220 ⁽¹⁾	
Nominal Effective Area	inch ²	69	69	105	156	105	156	220	
	cm ²	445	445	667	1006	677	1006	1419	
Yoke Boss Diameter	inch	2-1/8	2-13/16	2-13/16	2-13/16	3-9-16	3-9/16	3-9/16	
	mm	54	71	71	71	90	90	90	
Acceptable Valve Stem Diameter	inch	3/8	1/2	1/2	1/2	3/4	3/4	3/4	
	mm	9.5	12.7	12.7	12.7	19.1	19.1	19.1	
Maximum Allowable Output Thrust	lb	2300	2700	5650	7550	5650	6800	8800	
	N	10,230	12,010	25,131	33,582	25,131	30,246	39,142	
Maximum Travel⁽²⁾	Standard	inch	1-1/8	1-1/2	2	2	2	2	3 ⁽³⁾
		mm	29	38	51	51	51	51	76
	Top-Loaded	inch	3/4	---	3/4	---	---	1-1/8	---
		mm	19	---	19	---	---	29	---
Maximum Casing Pressure for Actuator Sizing^(4,5)	Psig	70	70	65	55	65	55	50	
	kPag	483	483	448	379	448	379	345	
Maximum Excess Diaphragm Pressure⁽⁴⁾	Psig	20	20	10	10	10	10	10	
	kPag	138	138	69	69	69	69	69	
Maximum Diaphragm Casing Pressure^(4,5)	Psig	90	90	75	65	75	65	60	
	kPag	621	621	517	448	517	448	414	
Approximate Weight	lbs	48	50	90	121	94	122	254	
	Kg	22	23	41	55	43	55	115	
Material Temperature Capabilities	Nitrile Elastomers	-40 to 180°F (-40 to 82°C)							
	Silicone Elastomers	-65 to 300°F (-54 to 149°C)							

NOTES:

- 1 These values also apply to the DFC Size 3220-4 actuator.
- 2 Actuator travel may be less than the value listed after connected to the valve.
- 3 Maximum actuator travel for the 3220-4 is 4 inches (102 mm).
- 4 See Specification section for definitions.
- 5 This Maximum Casing Pressure is not to be used for normal operating pressure. Its purpose is to allow for typical regulator supply settings and/or relief valve tolerances.



Model **DFC** Valve Actuator Operation, Parts and Instruction Manuals



Figure 2 Rigging Setup

Unpacking

Check the Packing List against materials received, while unpacking the actuator. The Packing List describes actuator and accessories in each shipping container.

When lifting the actuator from the shipping container, it is advisable to remove 2 actuator casing bolts, 180° apart, and temporarily replace them with eye bolts and nuts. Position the lifting straps through the eye bolts to avoid damage to the tubing and mounted accessories. See Figure 2.

Installation

! CAUTION !

Do not use an operating pressure that exceeds the Maximum Diaphragm Casing Pressure (See Table 1). Also make sure that the operating pressure does not create a force on the actuator stem that is greater than the Maximum Allowable Output Thrust (See Table 1)!

If the actuator has been installed on the valve in the factory, the assembly is ready to be placed inline. Refer to the proper Dyna-Flo valve manual for installation. Refer to the "Mounting: Actuator to Valve" section (Page 5) for detailed instructions on

how to install the actuator on the valve. The actuator must be installed on the valve before being installed into the pipeline. Ensure that the travel has been checked; refer to the "Bench Setting Actuator" section (below) for detailed instructions on this procedure.

Bench Setting Actuator

(Refer to Figure 3)

! CAUTION !

To prevent valve stem damage perform the bench setting with actuator removed from valve!

! CAUTION !

The following procedures must be completed before installing the stem connector (Key 22) between the actuator stem (Key 3) and the valve stem (Key 31). Except for the DFC Size 3220, the stem connector assembly (Key 22) will need to be installed to prevent the stem from rotating while adjusting the bench set.

- 1 To properly verify bench setting 3 pieces of information are required:
 - 1 Upper Bench Set Loading Pressure
 - 2 Lower Bench Set Loading Pressure (example: on a 10-30 Psig bench set, 10 is the lower and 30 Psig is the upper)
 - 3 Travel

This information is available on the actuator name plate (Key 33). If information is missing or incomplete contact your Dyna-Flo Sales Office.

- 2 Before applying pressure to the actuator make sure that the spring (Key 2) is properly seated onto the spring seat (Key 20) (not required on a new factory assembled actuator).
- 3 Connect a supply line with a gauge that can accurately measure both 0 Psi and the upper bench set pressure.
- 4 Apply maximum casing pressure to the actuator to verify seal integrity is good. Use a soapy solution to check for any air leaks from the lower casing gasket (Key 13) and the diaphragm (Key 7). On a new actuator this will have been done at the factory and won't be required.



Model
DFC Valve Actuator
Operation, Parts and Instruction Manuals

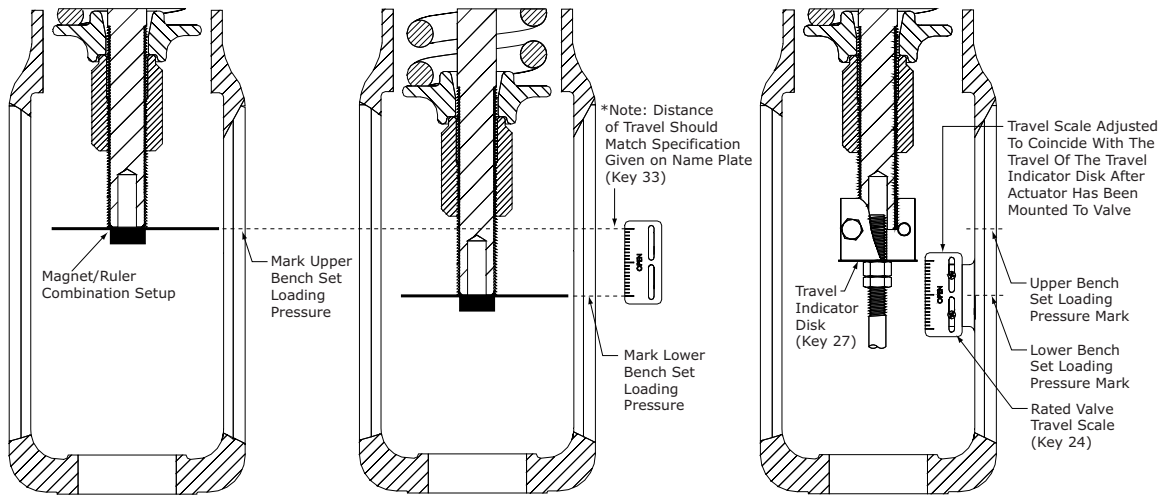

Figure 3 Bench Set Spring Adjustment Diagram

For Air to Open Valves

- 1 Apply the upper bench set loading pressure plus 5 Psi (34 kPa) to the actuator and note where stem travel stops, this should occur when the travel stop (Key 10) encounters the upper casing (Key 5). The intent is for the travel stop to contact the upper casing at the exact time the upper bench set loading value is reached. Apply 5 Psi (34 kPa) above and below the upper bench set value to verify this. (Example: for a 10-30 bench set the travel stop should contact the upper casing at exactly 30 Psig) If stem (Key 3) travel stops before or after the upper bench set value, the spring adjuster (Key 21) will need to be adjusted to obtain the proper bench set. You may need to relieve pressure to the actuator in order to adjust the spring adjuster. Turning the spring adjuster up (towards the top of the actuator) will increase the bench set pressure.
- 2 Once the upper bench set pressure has been set, use a magnet or piece of tape to attach a piece of metal or ruler to the bottom of the actuator stem (Key 3) to use as an indicator arm. Make a mark to indicate the stem position at the upper bench set pressure (See Figure 3). Make sure the travel is fully extended.
- 3 Adjust the gauge to the lower bench set pressure and mark the actuator stem position. The measurement between the upper and lower bench set marks should equal the travel indicated on the name-plate within 1/16" (1.6 mm).

! Note !

If these steps do not allow you to reach the proper bench set pressure then an incorrect or damaged spring may be the problem. Contact your Dyna-Flo Sales Office for more information.

Mounting: Actuator to Valve

! CAUTION !

During mounting the actuator stem and valve stem could come into contact with each other. Ensure that the valve stem is pushed down before trying to install the actuator, doing this will help to protect the stem threads from getting damaged.

! CAUTION !

It may be necessary to apply loading pressure to the actuator temporarily to move the actuator stem and allow for more clearance between it and the valve stem. Use extreme caution when moving the pressurized actuator; ensure that no clothing, hair, hands or tools come in between the two stems or moving parts. If loading pressure fails personal injury or property damage may occur.

- 1 Make sure the valve is securely supported using a vice or similar method before proceeding. It is advised to place valve on a surface that will be able to support the combined weight of valve and actuator.



Model **DFC** Valve Actuator Operation, Parts and Instruction Manuals

Mounting: Actuator to Valve (cont'd)

- 2 Make sure the stem is pushed down away from the actuator. Thread the two nuts (Keys 28 & 29) all the way onto the valve stem. Install the travel disk (Key 27) onto the valve stem (concave side down) so that it rests on the jam nuts. Note: with the travel disk on the stem it may not be possible to mount the actuator because the travel disk will not slide through the yoke boss mounting area. Before attempting to mount the actuator check to see that the disk will go through the yoke boss mounting area. If not, the travel disk will need to be inserted on the stem after the yoke nut (Key 32). Place the travel disk overtop of the yoke nut during the yoke nut installation process.
- 3 Be sure to have the yoke nut (Key 32) sitting inside the actuator yoke or have the yoke nut ready to be placed in between the actuator stem and valve stem when lowering the actuator onto the valve. Carefully lift and lower the actuator onto the valve, this may require more than one person or a heavy lifting device. Once on the valve, orientate the actuator to be properly aligned parallel with the valve body (see Figure 5).
- 4 Thread the yoke nut onto the valve bonnet and tighten using a heavy blunted chisel and hammer until the yoke is secured tightly to the valve (Refer to Figure 4). **DO NOT OVER TIGHTEN.**

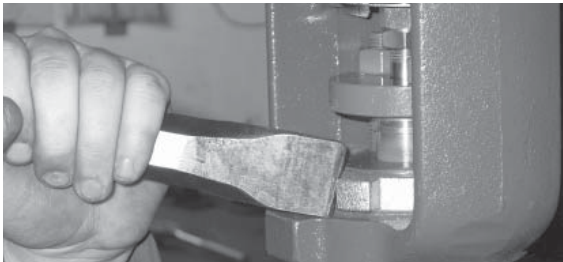

Figure 4 Yoke Nut Tightening

Stem Connector Installation

- 1 Apply upper loading pressure plus 5 Psi (34 kPa) to the actuator if loading pressure was not applied prior to mounting. This should put the actuator in the fully up position.
- 2 Install the travel scale (Key 24) to the actuator using the speed nuts (Key 26) and machine screws (Key 25). Position the travel disk (Key 27) on top of the jam nuts at the bottom of the travel scale (Key 24) by adjusting the jam nuts (Keys 28 & 29). Carefully move the plug / stem up until the travel disk indicates full travel as indicated on the travel scale. The movement of the plug / stem must be done with caution not to damage the stem.
- 3 As shown in Figure 3, the valve stem should fit inside the actuator stem. Install the stem connector (Key 22). It is important to position the stem connector so that the threads properly engage with those of the stems. Connect the other half of the stem connector and orientate the stem connector as show in Figure 3. It is at this time that any accessories (such as positioner arms) that need to be connected to the stem connector should be put in place. Install the stem connector bolts and tighten.
- 4 Re-position the travel disk (Key 27) under the stem connector (Key 22), thread up the jam nuts (Keys 28 & 29) to hold the travel disk in place and tighten the jam nuts together (Refer to Figure 3). Do not over tighten the jam nuts.
- 5 Apply pressure and stroke the valve several times. Loosen the travel scale (Key 24) and reposition it to align with the closed position of the valve and verify that the travel is still accurate to the value indicated on the name plate (Key 33). If travel is inaccurate it may be necessary to repeat the stem connector procedures or to refer back to Bench Setting Actuator.



Model **DFC** Valve Actuator Operation, Parts and Instruction Manuals

Maintenance

! WARNING !

Disconnect all power lines and pneumatic lines making sure the actuator is depressurized prior to commencing disassembly. Remove any power source that may cause the actuator to spontaneously move. Also, relieve any spring pressure or compression before you start the disassembly process, this can be done by lowering the spring adjuster (Key 21).

! CAUTION !

Use bypass valves or completely shut off process media to isolate the valve from the process pressure and fluids. Relieve process pressure and drain process media from both side of the valve.

Actuator Disassembly

- 1 Make sure that the valve and actuator are securely supported and that valve body is clamped in place and unable to move during disassembly.
- 2 Completely remove spring compression by turning the spring adjuster (Key 21) until loose. Once spring compression is removed disassemble the stem connector (Key 22) and remove both halves. Inspect all the threads on both halves of the stem connector and make sure there is no damage.
- 3 If removal of the actuator from the valve is necessary, the yoke nut (Key 32) will need to be completely loosened. Using a heavy blunted chisel and hammer, completely loosen the yoke nut (Key 32) (Refer to Figure 4). Note: the yoke nut will not be able to be removed until the actuator is lifted from the valve (Refer to Unpacking and Mounting sections for actuator hoisting instructions).
- 4 Before work begins make sure that the actuator is secured in place and properly supported.

Spring removal

- 1 Unscrew the spring adjuster (Key 21) and remove it from the actuator stem. With the spring adjuster removed it is possible to remove the spring seat (Key 20) from the yoke (Key 1). Inspect the threads of the spring adjuster and for damage and corrosion. Also, inspect the spring.

Upper Diaphragm Casing Disassembly

- 1 Remove all the diaphragm casing cap screws (Key 18) and nuts (Key 19). Lift the upper diaphragm casing (Key 5) from the actuator.
- 2 From the top of the open actuator remove the hex head bolt (Key 11) and travel stop (Key 10). The actuator stem (Key 3) may rotate during hex head bolt removal, it may be necessary to hold the stem or tap the wrench with a hammer to loosen the bolt. Use extreme caution and avoid damaging the actuator stem during this process. Remove the stem from the yoke mounting end.
- 3 Being careful not to damage the actuator stem (Key 3) remove it from the actuator. Inspect the actuator stem for thread damage, deep scratches and corrosion. Minor scratches and corrosion can be polished out (scratches that will not stop your fingernail are considered minor), if there are deep scratches, corrosion or damage the actuator stem will need to be replaced.
- 4 Remove the upper diaphragm plate (Key 8) from the actuator and diaphragm (Key 7), inspect the plate for cracks and wear. Note: on older actuators the upper diaphragm plate maybe composed of two separate pieces. Inspect the diaphragm for tears, abnormal stretching, cracks and pliability. If the diaphragm is brittle, torn or cracked it will need to be replaced.
- 5 Remove the lower diaphragm plate and inspect it for any cracks, wear or corrosion.
- 6 Using a pair of pliers or other tool, remove the snap ring (Key 14) from the yoke (it sits overtop of the bushing (Key 15)). Replace if necessary.



Model **DFC** Valve Actuator Operation, Parts and Instruction Manuals

Maintenance

(cont'd)

Upper Diaphragm Casing Disassembly

(cont'd)

- 7 Remove the bushing (Key 15) from the actuator being careful not to damage the bushing, seals or actuator yoke. The actuator stem (Key 3) and spring adjuster (Key 21) may be used with extreme caution to remove the bushing. By threading the spring adjuster part way onto the actuator stem the assembly may be inserted up into the yoke and used as a plunger to push out the bushing.
- 8 Using a pick set or small screwdriver, remove the o-rings (Keys 16 & 17) from the bushing being careful not to damage bushing surfaces. Inspect the sealing surfaces of the bushing for deep scratches and corrosion, replace if necessary. O-rings and gaskets should normally be replaced during maintenance.

Lower Diaphragm Casing Removal

- 1 Remove the lower diaphragm casing cap screws (Key 18) and lift lower diaphragm casing (Key 4) off of the yoke (Key 1). Remove the lower casing gasket (Key 13) clean and inspect the yoke / lower casing sealing surfaces for damage. O-rings and gaskets should be replaced during maintenance.

! NOTICE !

For the DFC Size 3220 inspect the o-ring groove on the top surface of the yoke (Key 1) for any deep scratching or corrosion. Also check the lower diaphragm casing (Key 4) for any deformation excessive tightening may have caused. O-rings and gaskets should be replaced during maintenance.

Actuator Assembly

! CAUTION !

Before assembling the actuator, make sure that the yoke and actuator are securely supported with a clamping device and on a surface that will support the assembled actuator weight.

! NOTICE !

Use an anti-seize compound that is approved for the service conditions that the actuator is being installed into.

Lower Diaphragm Casing Bushing Installation

- 1 Coat the lower diaphragm gasket (Key 13) with anti-seize compound and place on to the yoke (Key 1) (on a DFC size 3220 actuator there is an o-ring in place of the gasket). The holes of the gasket should align with the holes on the yoke.
- 2 Install the lower diaphragm casing (Key 4), tighten cap screws (Key 12) using a criss-cross pattern. DO NOT over tighten the cap screws as excessive tightening could warp the casing or deflect and cause the gasket to leak.
- 3 Lubricate the bushing seals (Keys 16 & 17) with silicone-based lubricant and place them into the bushing (Key 15) as shown in Figure 6. Pack the inside of the bushing with lubricant (Lubriplate® Mag-1 or equivalent) and insert the bushing into the yoke (Key 1). The bushing is held in place with the snap ring (Key 14) that fits into the groove in the yoke above the bushing (Refer to Figure 6).

Spring Installation

! NOTICE !

It may be desirable to have an appropriately sized block of wood nearby to be placed in the bottom of the yoke to be used as support for the stem/spring assembly while working on the actuator.

- 1 Coat the stem (Key 3) threads with anti-seize compound and thread the spring adjuster (Key 21) onto the stem. Place the spring seat (Key 20) onto the stem so that it rests on the spring adjuster as show in Figure 7.
- 2 Insert the spring (Key 2) into the barrel on the yoke (Key 1) and slide stem assembly from Step 1 into the yoke. It may be necessary to support the spring/stem assembly using a block of wood or similar item while assembling the upper portion of the actuator.



Model
DFC Valve Actuator
Operation, Parts and Instruction Manuals

Maintenance

(cont'd)

Upper Diaphragm Casing Assembly

- 1 Place the lower diaphragm plate (Key 6) into the lower diaphragm casing (Key 4) and onto the actuator stem (Key 3) as shown in Figure 7. Insert the diaphragm (Key 7) into the lower casing over the lower diaphragm plate and align the holes on the diaphragm with those of the lower casing.
- 2 Install the upper diaphragm plate (Key 8) onto the actuator stem so that it rests in the diaphragm (for a two piece diaphragm plate design both parts of the plate will need to be installed Figure 6 Key 9).
- 3 Place the travel stop (Key 10) over the actuator stem so that it rests on the upper diaphragm plate. Coat the threads of the hex head bolt with anti-seize and thread it into the top of the actuator stem (Key 3), tighten the hex head bolt completely making sure that the holes on the diaphragm still align with those of the lower casing (Refer to Torque Chart on Page 11).
- 4 Lift and place the upper diaphragm casing (Key 5) onto the top of the actuator, make sure that the holes of the upper casing align with those of the lower casing (Key 4) and diaphragm (Key 7). Install the casing cap screws (Key 18) into the casings, Do Not coat the cap screws with anti-seize. Thread the nuts (Key 19) onto the casing cap screws, Do Not over tighten the cap screws refer to Torque Chart on Page 11. Tighten the casing cap screws in a crisscross pattern to half required torque and in the same pattern completely tighten cap screws to full torque. In a circular pattern re-tighten the casing cap screws (Key 18) to full torque.
- 5 Refer to Bench Setting Actuator portion of manual to complete the actuator assembly.

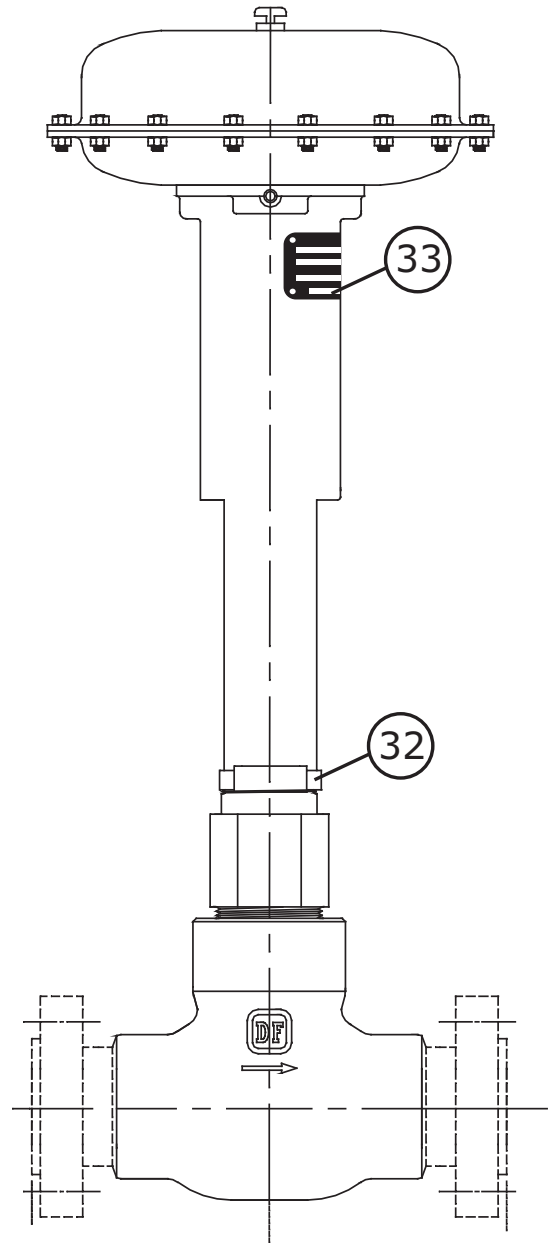

Figure 5 Actuator & Valve Mounting Diagram



Model **DFC** Valve Actuator Operation, Parts and Instruction Manuals

Casing-Mounted Travel Stops

! NOTICE !

For casing-mounted travel stop options refer to Figure 8. These options are available to limit travel in both down and up directions.

Adjusting Casing-Mounted Travel Stops

- 1 Remove the travel stop caps (Key 34, Types 3 & 4) and loosen jam nuts (Key 40) if they impede adjustments in Step 2.
- 2 Use the jam nuts (Key 40, Type 3), the extension stem (Key 39, Type 4) and travel stop screw (Key 37, Type 5) to adjust the travel limit.
- 3 After adjustments have been made, it will be necessary to re-tighten the jam nuts (Key 40) and replace the travel stop caps (Key 34, Types 3 & 4).

Casing-Mounted Travel Stop Disassembly

! NOTICE !

For maintenance purposes it is only necessary to disassemble the travel stops as far as need be to accomplish the required maintenance.

- 1 Remove the travel stop cap (Key 34). For down travel stops (Type 3) the jam nuts (Key 40) must be loosened so that the travel stop is not causing any spring compression.

! WARNING !

Disconnect all power lines and pneumatic lines making sure the actuator is depressurized prior to commencing disassembly. Remove any power source that may cause the actuator to spontaneously move. For down travel stops relieve any spring pressure or compression before you start the disassembly process, this can be done by lowering the spring adjuster (Key 21).

! CAUTION !

Use bypass valves or completely shut off process media to isolate the valve from the process pressure and fluids. Remove any tubing or piping from the connection on top of the yoke (Key 32).

- 2 Using a wrench on the jam nuts (Key 40) unscrew the extension stem (Key 39) and remove it. Inspect the extension stem for damage or corrosion, replace if necessary.
- 3 Remove all the diaphragm casing cap screws (Key 18) and nuts (Key 19). Lift the upper diaphragm casing (Key 5) from the actuator. For Types 3 and 4 the travel stop assembly will be removed with the upper diaphragm casing.
- 4 Record the position of the travel stop (Key 36) compared to the cap screws (Key 42) for reassembly purposes. Remove the travel stop and cap screws.
- 5 Inspect all travel stop parts for damage or corrosion and replace if necessary.

Casing-Mounted Travel Stop Assembly

- 1 Reassembly the actuator parts in reverse order starting at Step 4 of the Casing-Mounted Travel Stop Disassembly, be sure to apply anti-seize compound to the threads of the extension stem (Key 39). Return the cap screws (Key 42) and travel stop (Key 36) to their original position as recorded in Step 4. Refer to the Upper Diaphragm Casing Assembly procedures on Page for instruction on casing reassembly.
- 2 Retighten the spring adjuster (Key 21) to its original position and adjust the travel stops to their desired limits as per Adjusting Casing-Mounted Travel Stop procedures.



Model
DFC Valve Actuator
 Operation, Parts and Instruction Manuals

Table 2

Model DFC Actuator Torque Chart

Actuator Stem Hex Head Bolt Torque (Key 11)

Actuator Size	Ft-lbs.	N•m
1069	30	41
2069	50	68
2105, 2156, 3105, 3156, 3220	135	183

Casing Cap Screws Torque (Keys 18 & 19)

All Sizes	Ft-lbs.	N•m
Full Torque	20	27

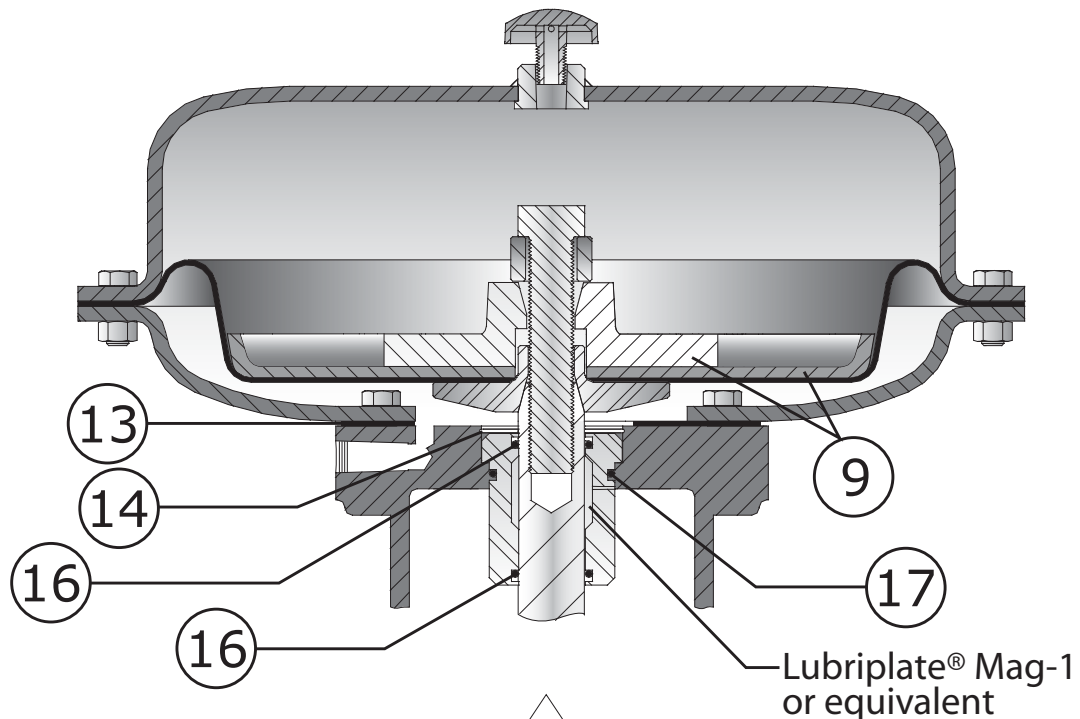

Figure 6 Model DFC Actuator Cross Section (2 Piece Diaphragm Plate Design)

Our Commitment of Quality

Dyna-Flo is committed to continuous improvement. All efforts have been taken to maximize the accuracy of this information. Without notification, product specifications and designs may be modified at any time. The issue of this document is for information only, and does not imply suitability, a warranty, or guarantee for a specific service.



Model
DFC Valve Actuator
 Operation, Parts and Instruction Manuals

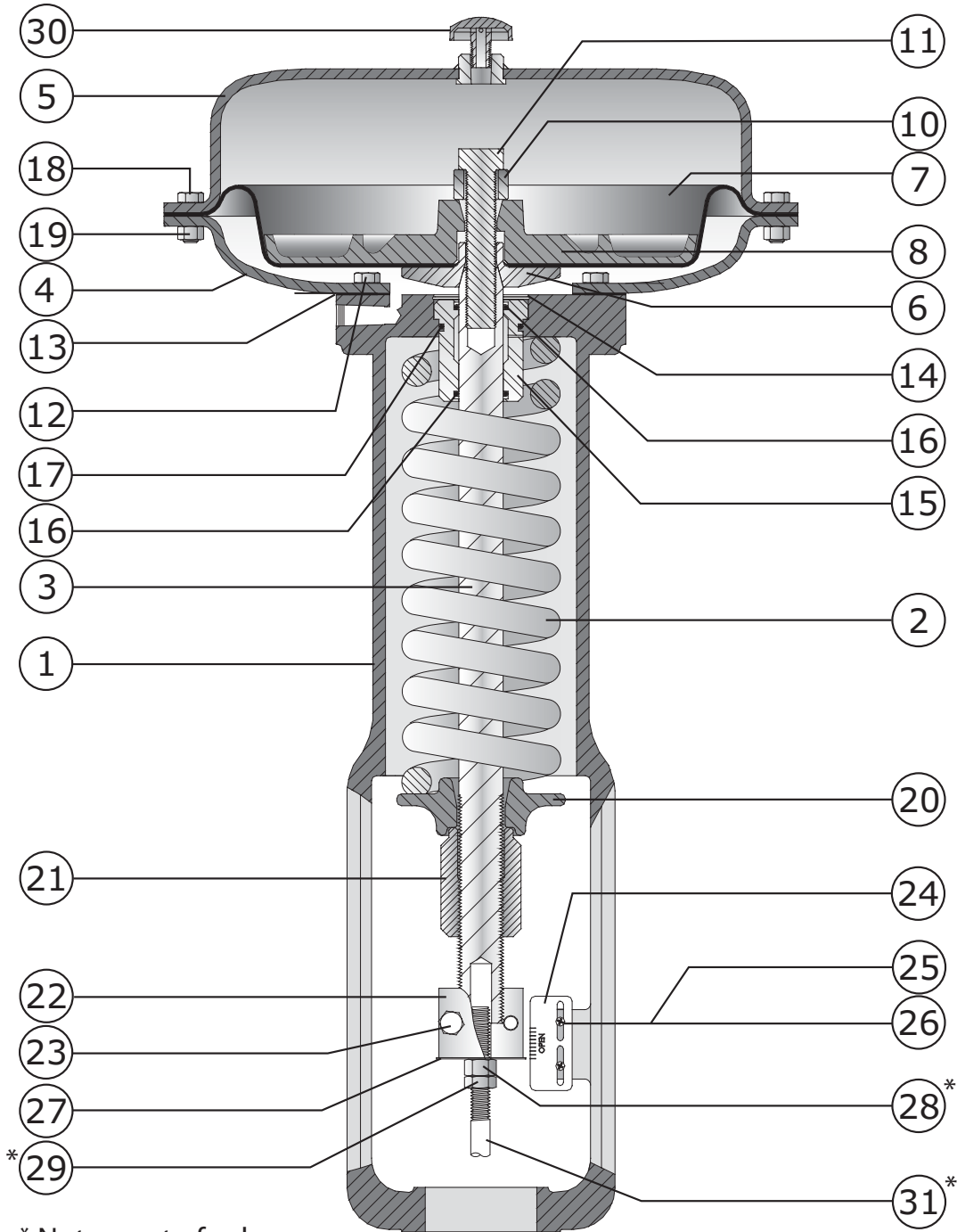

* Note: part of valve
 body assembly.

Figure 7 Model DFC Actuator Cross Section



Model
DFC Valve Actuator
 Operation, Parts and Instruction Manuals

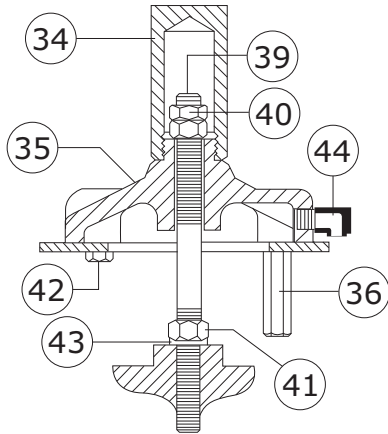

**TYPE 3
 DOWN STOP DFC**

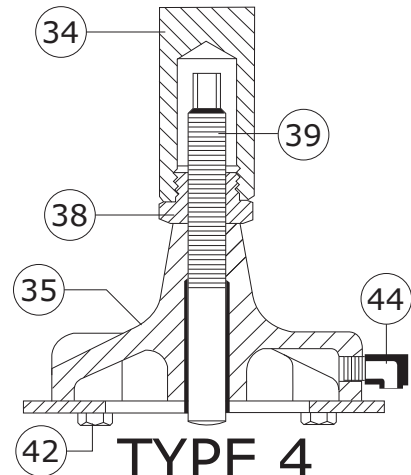

**TYPE 4
 UP STOP DFC**

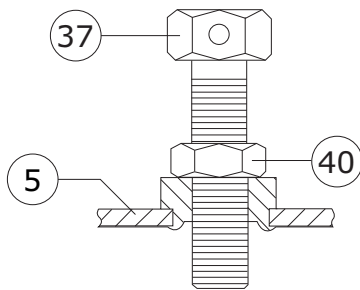

**TYPE 5
 UP STOP DFC**

Figure 8 Model DFC Actuator Cross Section



Model
DFC Valve Actuator
 Operation, Parts and Instruction Manuals

Parts

Key	Description	Part Number
1	Yoke <i>Cast Iron</i>	
	Size 1069	3E88461904D
	Size 2069	3E82081904D
	Size 2105 & 2156	3E90081904D
	Size 3105 & 3156	3E84591904D
	Size 3220	3N13031904D
2	Spring <i>Steel</i> (See Table 4, Page 18)	
3	Stem <i>17-4</i>	
	Size 1069	3E8847X174D
	Size 2069	2E8209X174D
	Size 2105 & 2156	2J3328X174D
	Size 3105 & 3156	2E8461X174D
	Size 3220	2N13172174D
	Size 3220-4	21A3812X01D
4	Lower Diaphragm Casing <i>Steel</i>	
	Size 1069 & 2069	2E68262506D
	Size 2105 & 3105	3E84532506D
	Size 2156 & 3156	3E84772506D
	Size 3220 & 3220-4	2N13102506D
5	Upper Diaphragm Casing <i>Steel</i>	
	Size 1069 & 2069	2E68142899D
	Size 2105 & 3105	3E84462899D
	Size 2156 & 3156	3E84672899D
	Size 3220	2N12782899D
6	Lower Diaphragm Plate <i>Steel</i>	
	Size 1069 & 2069	1F88582409D
	Size 2105, 2156, 3105, 3156	1F89094402D
	Size 3220	1N13152409D
7	Diaphragm <i>Nitrile / Nylon</i>	
	Size 1069 & 2069	2E66990220D
	Size 2105 & 3105	2E85960220D
	Size 2156 & 3156	2E85980220D
	Size 3220	2N13090220D
8	Upper Diaphragm Plate <i>Cast Iron</i>	
	Size 1069 & 2069	31B2029904D
	Size 2105 & 3105	41B2030904D
	Size 2156 & 3156	2E84751904D
	Size 3220	2N12701904D
9	Upper Diaphragm Plate (2 Piece Design) <i>Zinc Plated Steel</i>	
10	Travel Stop <i>Steel</i> (See Table 3, Page 17)	
11	Actuator Stem Hex Head Bolt <i>Zinc Plated Steel</i> (See Table 3, Page 17)	
12	Hex Head Cap Screw <i>Zinc Plated Steel</i>	
	Size 1069 & 2069 (Qty. 6)	H5CZ38.034
	Size 2105, 2156, 3105, 3156 (Qty. 8)	H5CZ38.034
	Size 3220 (Qty. 12)	H5CZ12.100
13	Gasket <i>Composition</i>	
	Size 1069 & 2069	1E80120402D
	Sizes 2105, 2156, 3105, 3156	1E84540402D
	Size 3220 (O-Ring Nitrile)	1D26910699D
14	Snap Ring <i>SST</i>	
	Size 1069 & 2069	1E80133702D
	Size 2105, 2156, 3105, 3156, 3220	1E84563899D
15	Bushing <i>Brass</i>	
	Size 1069 & 2069	1E68281401D
	Size 2105, 2156, 3105, 3156	1E84571401D
	Size 3220	1N1316X005D
16	O-Ring <i>Buna (Qty. 2)</i>	
	Size 1069 & 2069	1D23750699D
	Size 2105, 2156, 3105, 3156	1C56220699D
	Size 3220	1E73690699D
17	O-Ring <i>Buna</i>	
	Size 1069 & 2069	1C41570699D
	Size 2105, 2156, 3105, 3156, 3220	1E84580699D
18	Hex Head Cap Screw (casing) <i>Zinc Plated Steel</i>	
	Size 1069 & 2069 (Qty. 16)	H5FZ38.100
	Size 2105 & 3105 (Qty. 20)	H5FZ38.100
	Size 2156 & 3156 (Qty. 24)	H5FZ38.100
	Size 3220 (Qty. 28)	H5FZ38.114



Model
DFC Valve Actuator
 Operation, Parts and Instruction Manuals

Parts

Key	Description	Part Number		
19	Hex Nut (casing)		Size 2069, 2105, 2156 1A41322412D	
	<i>Zinc Plated Steel</i>		Size 3105, 3156, 3220 1A37542412D	
	Size 1069 & 2069 (Qty. 16)	NHFZ38		
	Size 2105 & 3105 (Qty. 20)	NHFZ38		
	Size 2156 & 3156 (Qty. 24)	NHFZ38		
	Size 3220 (Qty. 28)	NHFZ38		
20	Spring Seat			
	<i>Steel Pl.</i>			
	Size 1069 & 2069	1R17992312D		
	Size 2105, 2156, 3105, 3156	1R18002312D		
	3220	1N12961905D		
21	Spring Adjuster			
	<i>Steel Pl.</i>			
	Size 1069 & 2069	1E82102410D		
	Size 2105, 2156, 3105, 3156	1E84622410D		
	Size 3220	1N13181X01D		
22	Stem Connector Assembly			
	<i>Steel Pl.</i>			
	Size 1069	18A1243X01D		
	Size 2069	18A1668X01D		
	Size 2105 & 2156	18A1671X01D		
	Size 3105 & 3156	18A1672X01D		
	Size 3220	18A1675X01D		
23	Stem Connector bolt			
	<i>Part of Stem Connector Assembly (Qty. 2)</i>			
24	Travel Scale			
	<i>SST</i>			
	(See Table 3, Page 17)			
25	Machine Screw			
	<i>SST (Qty. 2)</i>			
	Size 1069, 2069, 2105, 2156	1E79323899D		
	Size 3105, 3156, 3220	1E83133899D		
26	Speed Nut			
	<i>SST (Qty. 2)</i>	242-206		
27	Travel Disk			
	<i>SST</i>			
	Size 1069	1E79313899D		
	Size 2069, 2105, 2156	1E80753899D		
	Size 3105 & 3156	1E83283899D		
	Size 3220	1B97183899D		
28	Stem Nut			
	<i>Steel Pl.</i>			
	Size 1069	1P13122414D		
29	Jam Nut			
	<i>Steel Pl.</i>			
	Size 1069	1P13122414D		
	Size 2069, 2105, 2156	1A35372412D		
	Size 3105, 3156, 3220	1A35112412D		
	30	Vent Cap		
		<i>Plastic</i>	Y602-1BD	
	31	Valve Stem		
	32	Yoke Nut		
	33	Actuator Name Plate		
34	Travel Stop Cap			
	<i>Brass</i>			
	Type 3			
	Size 1069 & 2069	1F59781401D		
	Size 2105, 2156, 3105, 3156	1H11111401D		
	Size 3220	1R38761401D		
	Type 4			
	Size 1069 & 2069	1F59781401D		
	Size 2105, 2156, 3105, 3156	1F83961401D		
	Size 3220	1R38761401D		
	<i>Steel</i>			
	Type 4			
	Size 1069 & 2069	1F59782409D		
35	Travel Stop Body			
	<i>Cast Iron</i>			
	Type 3			
	Size 1069 & 2069	1K72351901D		
	Size 2105, 2156, 3105, 3156	2K72301901D		
	Size 3220	2U14181902D		
	Type 4			
	Size 1069 & 2069	37A9437X01D		
	Size 2105, 2156, 3105, 3156	37A9432X01D		
	Size 3220	37A9661X01D		
36	Casing-Mounted Travel Stop			
	<i>Steel</i>			
	(See Table 5, Page 19)			



Model
DFC Valve Actuator
 Operation, Parts and Instruction Manuals

Parts

Key	Description	Part Number
37	Travel Stop Screw	
	<i>Steel</i>	
	Type 5	
	Size 1069 & 2069	1F75373513D
	Size 2105, 2156, 3105, 3156	1K13113513D
	Size 3220	13A2133X01D
38	Travel Stop Nut	
	<i>Brass</i>	
	Type 4	
	Size 1069 & 2069	18A2303X01D
	Size 2105, 2156, 3105, 3156	18A1272X01D
39	Extension Rod (Stem)	
	<i>Steel</i>	
	Type 3	
	Size 1069 & 2069	1F75363503D
	Size 2105, 2156, 3105, 3156	1J23273503D
	Size 3220	1V7764X00AD
	<i>Bronze</i>	
	Type 4	
Size 1069 & 2069	27A9655X01D	
	Size 2105, 2156, 3105, 3156	27A9656X01D
	Size 3220	27A9763X01D
40	Hex Head Jam Nut	
	<i>Zinc Plated Steel</i>	
	Size 1069 & 2069	1A35372412D
	Size 2105, 2156, 3105, 3156, 3220	1A35112412D
41	Hex Nut	
	<i>Zinc Plated Steel</i>	
	Type 3	
	Size 1069 & 2069	1A41322412D
	Size 2105, 2156, 3105, 3156, 3220	1A37542412D
42	Hex Head Cap Screw	
	<i>Zinc Plated Steel</i>	
	Type 3	
	Size 1069, 2069, 2105, 2156, 3105, 3156	1A36842405D
	Size 3220	1N12932899D
	Type 4	
	Size 1069, 2069, 2105 2105, 2156, 3105, 3156	1A36842405D
	Size 3220	1N12932899D
43	Lock Washer	
	<i>Steel</i>	
	Size 1069 & 2069	1A48782899D
	Size 2105, 2156, 3105, 3156	1A87322899D
	Size 3220	1A54932898D
44	Elbow Vent	
	<i>Plastic</i>	
	Size 1069, 2069, 2105, 2156, 3105, 3156	27A5516X01D
	Size 3220	17A6572X02D



Model
DFC Valve Actuator
 Operation, Parts and Instruction Manuals

Table 3

Keys 10, 11 & 24 Actuator Stem Hex Head Bolt, Travel Stop and Travel Scale

Actuator Size	Travel inch (mm)	Hex Head Bolt	Travel Stop	Travel Scale
1069	3/4 (19)	1R4089X004D	1R40952409D	1E79363999D
	1-1/8 (29)	1R4091X003D	1R40962409D	17A9814X01D
2069	3/4 (19)	1R4089X004D	1R40952409D	1E80813899D
	1-1/8 (29)	1R4091X003D	1R40962409D	1E80823899D
	1-1/2 (38)	1R4092X002D	1R40972409D	1E80833899D
2105	3/4 (19)	1R4098X002D	1R41052409D	1E80813899D
	1-1/8 (29)	1R4099X002D	1R41082409D	1E80823899D
	1-1/2 (38)	1R4101X002D	1R41062409D	1E80833899D
	2 (51)	1R4102X001D	1R41072409D	1R44453898D
2156	3/4 (19)	1R4098X002D	1R41052409D	1E80813899D
	1-1/8 (29)	1R4099X002D	1R41082409D	1E80823899D
	1-1/2 (38)	1R4101X002D	1R41062409D	1E80833899D
	2 (51)	1R4102X001D	1R41072409D	1R44453898D
3105	3/4 (19)	1R4098X002D	1R41052409D	1E83313899D
	1-1/8 (29)	1R4099X002D	1R41082409D	1E83323899D
	1-1/2 (38)	1R4101X002D	1R41062409D	1E83333899D
	2 (51)	1R4102X001D	1R41072409D	1E83343899D
3156	3/4 (19)	1R4098X002D	1R41052409D	1E83313899D
	1-1/8 (29)	1R4099X002D	1R41082409D	1E83323899D
	1-1/2 (38)	1R4101X002D	1R41062409D	1E83333899D
	2 (51)	1R4102X001D	1R41072409D	1E83343899D
3220	3/4 (19)	1R4110X001D	1R41162409D	1H74573899D
	1-1/8 (29)	1R4110X001D	1R41152409D	1H74583899D
	1-1/2 (38)	1R4098X002D	1R41142409D	1H74593899D
	2 (51)	1R4099X002D	1R41132409D	1H74603899D
	3 (76)	1R4102X001D	1R41072409D	1H74613899D



Model
DFC Valve Actuator
 Operation, Parts and Instruction Manuals

Table 4

Key 2 Actuator Spring Chart

Actuator Size	Travel inch (mm)	Diaphragm Pressure Range Psig (kPag)	
		3-15 (21-103)	6-30 (41-207)
1069	3/4 (19)	1E80582708D (light grey)	1E80522708D (orange & red)
	1-1/8 (29)	1E80532709D (dark grey)	1E80552708D (dark blue)
2069	3/4 (19)	1E80582708D (light grey)	1E80522708D (orange & red)
	1-1/8 (29)	1E80532709D (dark grey)	1E80552708D (dark blue)
	1-1/2 (38)	1E80562709D (dark green)	1E80582708D (light grey)
2105	3/4 (19)	1E82622708D (light green)	1E82552708D (aluminum & red)
	1-1/8 (29)	1E82612708D (dark grey)	1E82642708D (light grey)
	1-1/2 (38)	1E82662708D (orange)	1E82622708D (light green)
	2 (51)	1E82692708D (dark green)	1E82652708D (red)
2156	3/4 (19)	1E82572708D (brown)	1E82602708D (bronze)
	1-1/8 (29)	1E82622708D (light green)	1E82552708D (aluminum & red)
	1-1/2 (38)	1E82652708D (red)	1E82572708D (brown)
	2 (51)	1E82702708D (aluminum & dark blue)	1E82632708D (aluminum & dark green)
3105	3/4 (19)	1E82622708D (light green)	1E82552708D (aluminum & red)
	1-1/8 (29)	1E82612708D (dark grey)	1E82642708D (light grey)
	1-1/2 (38)	1E82662708D (orange)	1E82622708D (light green)
	2 (51)	1E82692708D (dark green)	1E82652708D (red)
3156	3/4 (19)	1E82572708D (brown)	1E82602708D (bronze)
	1-1/8 (29)	1E82622708D (light green)	1E82552708D (aluminum & red)
	1-1/2 (38)	1E82652708D (red)	1E82572708D (brown)
	2 (51)	1E82702708D (aluminum & dark blue)	1E82632708D (aluminum & dark green)
3220	3/4 (19)	1N12792708D (red)	---
	1-1/8 (29)	1N71932708D (white)	1N12812708D (brown)
	1-1/2 (38)	1N12872708D (yellow)	1N12792708D (red)
	2 (51)	1N12842708D (light green)	1N12852708D (light blue)
	3 (76)	1N12862708D (dark grey)	1N12872708D (yellow)



Model
DFC Valve Actuator
 Operation, Parts and Instruction Manuals

Table 5

Key 36 Casing-Mounted Travel Stop (Type 3)

Actuator Size	Travel inch (mm)	Travel Stop
1069	3/4 (19)	1E80662409D (Qty: 4)
	1-1/8 (29)	1E80672409D (Qty: 4)
2069	3/4 (19)	1E80662409D (Qty: 4)
	1-1/8 (29)	1E80672409D (Qty: 4)
	1-1/2 (38)	1E80682409D (Qty: 4)
2105	3/4 (19)	1E83192409D (Qty: 4)
	1-1/8 (29)	1E83192409D (Qty: 4)
	1-1/2 (38)	1E80642409D (Qty: 4)
	2 (51)	1E83212409D (Qty: 4)
2156	3/4 (19)	1E83192409D (Qty: 4)
	1-1/8 (29)	1E83192409D (Qty: 4)
	1-1/2 (38)	1E80642409D (Qty: 4)
	2 (51)	1E83212409D (Qty: 4)
3105	3/4 (19)	1E83192409D (Qty: 4)
	1-1/8 (29)	1E83192409D (Qty: 4)
	1-1/2 (38)	1E80642409D (Qty: 4)
	2 (51)	1E83212409D (Qty: 4)
3156	3/4 (19)	1E83192409D (Qty: 4)
	1-1/8 (29)	1E83192409D (Qty: 4)
	1-1/2 (38)	1E80642409D (Qty: 4)
	2 (51)	1E83212409D (Qty: 4)
3220	3/4 (19)	1N12882409D (Qty: 3)
	1-1/8 (29)	1N12892409D (Qty: 3)
	1-1/2 (38)	1N12902409D (Qty: 3)
	2 (51)	1N12914092D (Qty: 3)
	3 (76)	1N12922409D (Qty: 3)
3220-4	4 (102)	11A8131X01D (Qty: 3)



Model
DFC Valve Actuator
 Operation, Parts and Instruction Manuals

Ordering Guide

Dyna-Flo DFC / DFO Series Actuators | Model Numbering System

Sample Part Number

DFC - 2 069 - B H N - X

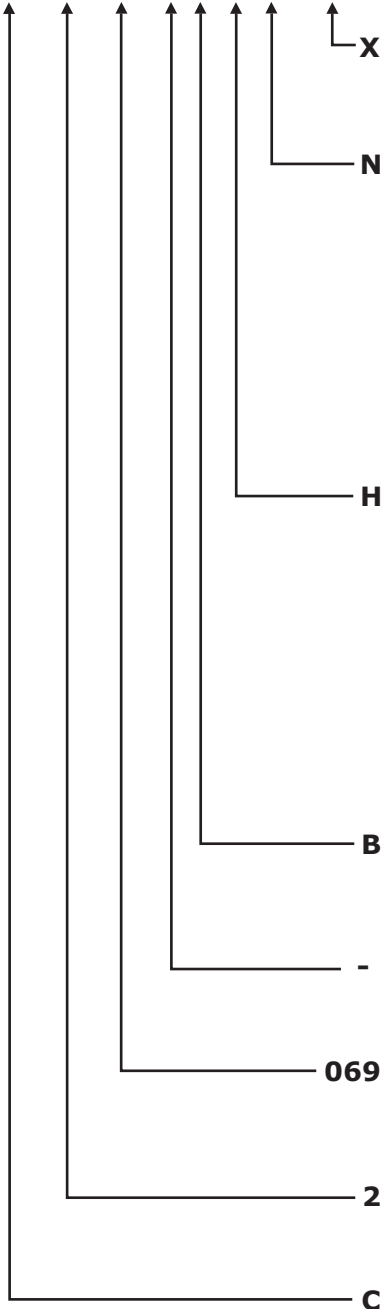

Denotes Special Construction
X Special (Consult Dyna-Flo Sales Office)

Options

N None (Standard)	2 Type 2 Down Stop - DFO
S Side Mounted Handwheel	3 Type 3 Down Stop - DFC
T Top Mounted Handwheel	4 Type 4 Up Stop - DFC
1 Type 1 Up Stop - DFO	5 Type 5 Up Stop - DFC

Bench Range, psig

FAIL CLOSED		FAIL OPEN	
A 3 - 15	H 6 - 30	A 3 - 15	H 6 - 30
B 4 - 15	Y 8 - 30	B 3 - 14	I 6 - 28
C 5 - 15	I 9 - 30	C 3 - 13	J 6 - 27
D 6 - 15	J 10 - 30	D 3 - 12	K 6 - 26
E 7 - 15	K 12 - 30	E 3 - 11	L 6 - 24
F 8 - 15	L 14 - 30	F 3 - 10	M 6 - 22
U 9 - 15	M 15 - 30	G 3 - 8	N 6 - 21
G 10 - 15	N 16 - 30	X Special	O 6 - 20
V 11 - 15	O 17 - 30		P 6 - 19
X Special	P 18 - 30		Q 6 - 18
	Q 19 - 30		R 6 - 17
	R 20 - 30		S 6 - 16
	S 21 - 30		T 6 - 15
	T 22 - 30		U 6 - 23
	W 14 - 26		

Travel, Inch

A 3/4	D 2	G 3-1/2
B 1-1/8	E 2-1/2	X Special Travel
C 1-1/2	F 3	

Paint

- Standard Dyna-Flo Paint	H Helix Spec. Paint
W International Paint - Willow Grey Color No. 80898	

Actuator Size, in²

069 69	156 156
105 105	220 220

Valve Yoke, Inch

1 2-1/8	S Short 2-13/16
2 2-13/16	
3 3-9/16	

Action

C Fail Closed	O Fail Open
----------------------	--------------------