



Model 390 Control Valve



Figure 1 Model 390 Control Valve with DFC Actuator

The Model 390 control valve (Figure 1) is a heavy duty globe style control valve. This valve is used in all kinds of demanding applications, including oil and gas production and chemical process. Metal seats are used for increased seat life.

Model 390 valves are cage guided, single port valves that can be used in either snap on/off acting or throttling applications of either liquids or gases. A bolted bonnet is standard and a typical actuator is a Dyna-Flo DFC or DFO model linear actuator.

Features

High Quality Construction

Dyna-Flo uses only materials that have been proven to provide superior, trouble free performance. All materials comply with ASME and ASTM specifications.

Versatility

A wide range of trim options including Anti-Cavitation and Low-Noise make the 390 a highly versatile control valve.

Field Service Friendly

No special tools are required to change or inspect trim. Top access makes in-line service easy.

Industrial High Quality External Coatings

Our standard industrial high quality external coatings provide long lasting resistance to the harshest environments.

Pressure Drop Capabilities

The Model 390 can shut off against inlet pressure equal to ASME B16.34 rating.

Sour Gas Service Capability

The Model 390 can be constructed out of materials that comply with the recommendations of the National Association of Corrosion Engineers (NACE) MR-0175.

Shut Off Classification

Seat leakage options range from ASME/FCI class II to class V.

Plug Design

Standard balanced plug design allows the use of smaller actuators.

Environmentally Friendly

Available with low emission live loaded packing.



Model 390 Control Valve

Specifications

Configurations

See Table 1.

Consult your Dyna-Flo sales office for other available configurations.

Sizes and Connection Styles

Model: 390
Size: 2", 3", 4", and 6"
Rating: ASME 900 or 1500
Connections: RF / RTJ (for other connection styles consult Dyna-Flo).

Maximum Inlet Temperatures and Pressures

Consistent with ASME class rating as per ASME B16.34, unless limited by either material, pressure or temperature limitations.

Maximum Pressure Drops

Same as maximum inlet pressure unless otherwise rated by specific trim construction. For Actuator and Valve assembly shut off pressure drops see Tables 11 and 12. For trim pressure/temperature ratings see Figure 5.

Standard Seat Leakage Classifications

See Table 1.

Dimensions

Valve and Actuator Assembly Dimensions
See Table 3 & 4, and Figure 2.

Approximate Valve Body and Actuator Weights

See Table 2.

Valve Body to Bonnet Bolting

Standard service body to bonnet:
SA193-B7 Studs
SA-194-2H Nuts

For NACE-2002
SA-193-B7M Studs
SA-194-2HM Nuts

Characteristics

- Equal Percentage (Standard)
- Modified Equal Percentage (Same cage as Equal Percentage, different travel)
- Linear
- Low-Noise 3
- Anti-Cavitation 2-Stage
- Anti-Cavitation 3-Stage

Packing Type

The standard packing is PTFE V-Ring. Live loaded low emission, graphite and other packing arrangements are also available.

Valve Sizing Coefficients

See Table 6, 7, 8, and 9.

Valve Travel and Yoke Boss Sizes

See Table 13.

Trim Materials

See Table 14.

Valve Bolting Temperature Limitations

See Table 15.

Valve Parts List, Material and Temperature Limitations

See Table 10, 14, 15, and 16.

See Figure 5 and 6.



Model
390 Control Valve

Table 1

Valve Design Configurations

Valve Model	Size (inch)	Shut Off Capability	Valve Plug	Seal Ring	Guide	Seat
390	2, 3, 4, 6	IV Standard	Balanced	Carbon PTFE with R30003 Spring	Cage	Metal
	2, 3, 4, 6	V Optional Standard For Anti-Cavitation Trim	Balanced	Carbon PTFE with R30003 Spring	Cage	Metal

Table 2

Approximate Weights lb (kg)

Valve Size (inch)	Class	Body Flanged	With Fail Open Actuator	Assembly Weight	With Fail Close Actuator	Assembly Weight
2	900 / 1500	160 (73)	DFO-2105	242 (110)	DFC-2105	250 (114)
3	900	275 (125)	DFO-2105	357 (162)	DFC-2105	365 (166)
3	1500	286 (130)	DFO-3156	402 (183)	DFC-3156	408 (185)
4	900	510 (231)	DFO-3156	626 (284)	DFC-3156	632 (286)
4	1500	552 (250)	DFO-3220	787 (357)	DFC-3156	806 (366)
6	900	1125 (510)	DFO-3220	1360 (617)	DFC-3220	1379 (626)
6	1500	1228 (557)	DFO-3220	1463 (664)	DFC-3220	1482 (672)



Model 390 Control Valve

Table 3

Models 390 Standard Valve Dimensions Inches (mm) (Refer to Figure 2)

Valve Size	ASME Class	Actuator Size	Dimension				
			A	B	D	D	E
					DFO	DFC	
2"	900 / 1500 RF	2105	14.75 (375)	3.06 (78)	25.90 (658)	30.30 (770)	16.00 (406)
	900 / 1500 RTJ	2105	14.88 (378)	3.06 (78)	25.90 (658)	30.30 (770)	16.00 (406)
3"	900 RF	2105	17.38 (441)	4.75 (121)	25.90 (658)	30.30 (770)	16.00 (406)
	900 RTJ	2105	17.50 (445)	4.75 (121)	25.90 (658)	30.30 (770)	16.00 (406)
	1500 RF	2156	18.13 (460)	4.75 (121)	25.80 (655)	29.40 (747)	18.62 (473)
	1500 RTJ	2156	18.25 (464)	4.75 (121)	25.80 (655)	29.40 (747)	18.62 (473)
3"	900 RF	3156	17.38 (441)	4.75 (121)	28.40 (721)	30.90 (785)	18.62 (473)
	900 RTJ	3156	17.50 (445)	4.75 (121)	28.40 (721)	30.90 (785)	18.62 (473)
	1500 RF	3156	18.13 (461)	4.75 (121)	28.40 (721)	30.90 (785)	18.62 (473)
	1500 RTJ	3156	18.25 (464)	4.75 (121)	28.40 (721)	30.90 (785)	18.62 (473)
4"	900 RF	3156	20.12 (511)	6.88 (175)	28.40 (721)	30.90 (785)	18.62 (473)
	900 RTJ	3156	20.25 (514)	6.88 (175)	28.40 (721)	30.90 (785)	18.62 (473)
	1500 RF	3220	20.88 (530)	6.88 (175)	33.10 (841)	36.80 (935)	21.12 (536)
	1500 RTJ	3220	21.00 (533)	6.88 (175)	33.10 (841)	36.80 (935)	21.12 (536)
6"	900 RF	3220	28.12 (714)	9.75 (248)	33.10 (841)	36.80 (935)	21.12 (536)
	900 RTJ	3220	28.25 (718)	9.75 (248)	33.10 (841)	36.80 (935)	21.12 (536)
	1500 RF	3220	30.25 (768)	9.75 (248)	33.10 (841)	36.80 (935)	21.12 (536)
	1500 RTJ	3220	30.50 (775)	9.75 (248)	33.10 (841)	36.80 (935)	21.12 (536)

Table 4

Model 390 Dimension C for Standard Bonnet Diameters

Inches (mm) (Refer to Figure 2)

Valve Size (Inch)	Dimension C		
	2-13/16 (71) Yoke Boss Diameter	3-9/16 (90) Yoke Boss Diameter	5 (127) Yoke Boss Diameter
2	10.31 (261)	10.56 (267)	—
3	12.69 (322)	12.25 (311)	—
4	—	11.81 (300)	—
6	—	14.38 (365)	15.81 (402)



Model
390 Control Valve

Table 5

Model 392 Dimension C for Extension Bonnets
Inches (mm) (Refer to Figure 2)

Valve Size	Dimension C		
	2-13/16 (71) Yoke Boss Diameter	3-9/16 (90) Yoke Boss Diameter	5 (127) Yoke Boss Diameter
1"	15.12 (384)	15.75 (400)	-
2" Standard	16.94 (430)	17.56 (446)	19.88 (505)
2" Anti-Cavitation 2-stage	17.62 (448)	18.25 (464)	20.38 (518)
2" Anti-Cavitation 3-stage	16.94 (430)	17.56 (446)	19.88 (505)

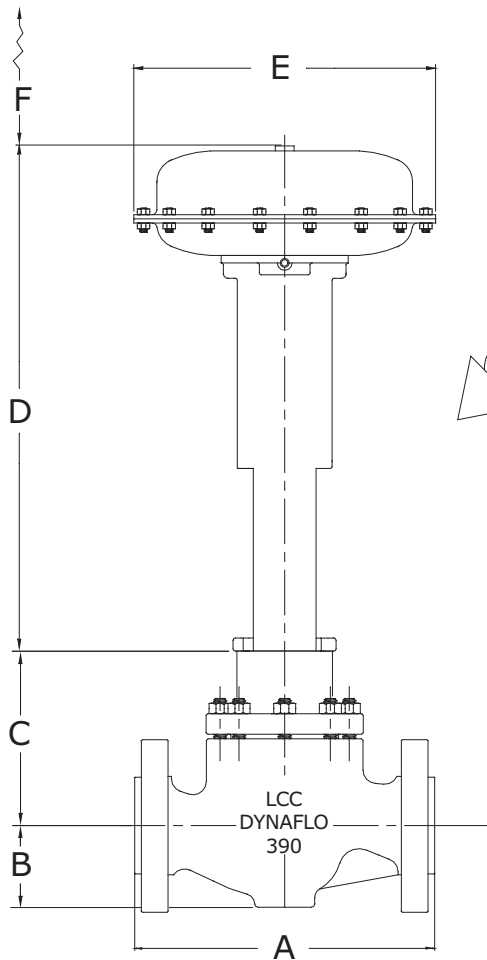

Figure 2 Typical Valve Assembly with Type DFC or DFO

F Dimension:

2" Valve	6.88" (175 mm)
3" Valve	6.88" (175 mm)
3" Valve	9.12" (232 mm)
For DFC/DFO 3156	
4" Valve	9.12" (232 mm)
6" Valve	9.12" (232 mm)



Model
390 Control Valve

Table 6

Models 390 Valve Sizing Coefficients

Linear - Flow Down

Valve Size	Port Inches (mm)	Travel Inches (mm)	Coefficient	Percentage of Valve Travel									
				10%	20%	30%	40%	50%	60%	70%	80%	90%	100%
2"	1-7/8 (47.6)	1-1/2 (38.1)	C _V	-	3.49	12.5	22.9	31.8	38.4	43.0	46.7	49.9	52.1
			X _T	-	0.811	0.632	0.682	0.743	0.829	0.78	0.743	0.726	0.697
			F _L	0.91	0.91	0.91	0.91	0.91	0.91	0.91	0.91	0.91	0.91
3"	2-7/8 (73)	2 (50.8)	C _V	-	8.72	31.5	55.1	74.6	89.4	101	110	117	121
			X _T	-	0.589	0.589	0.653	0.728	0.775	0.795	0.791	0.777	0.773
			F _L	0.93	0.93	0.93	0.93	0.93	0.93	0.93	0.93	0.93	0.93
4"	3-5/8 (92.1)	2 (50.8)	C _V	6.91	26.5	26.5	86.4	117	143	165	182	194	201
			X _T	0.327	0.581	0.581	0.509	0.525	0.602	0.673	0.708	0.714	0.726
			F _L	0.91	0.91	0.91	0.91	0.91	0.91	0.91	0.91	0.91	0.91
6"	5-3/8 (136.5)	3 (76.2)	C _V	8.78	63.3	149	231	298	351	385	407	424	425
			X _T	0.763	0.613	0.544	0.573	0.620	0.670	0.721	0.745	0.709	0.726
			F _L	0.91	0.91	0.91	0.91	0.91	0.91	0.91	0.91	0.91	0.91

Equal Percent - Flow Down

Valve Size	Port Inches (mm)	Travel Inches (mm)	Coefficient	Percentage of Valve Travel									
				10%	20%	30%	40%	50%	60%	70%	80%	90%	100%
2"	1-7/8 (47.6)	1-1/8 (28.6)	C _V	-	1.02	3.26	7.53	13.3	19.8	26.4	32.0	36.2	41.0
			X _T	-	0.745	0.619	0.595	0.587	0.593	0.633	0.721	0.791	0.791
			F _L	0.93	0.93	0.93	0.93	0.93	0.93	0.93	0.93	0.93	0.93
3"	2-7/8 (73)	1-1/2 (38.1)	C _V	-	1.21	4.21	11.3	23.0	37.6	53.2	69.5	85.3	92.5
			X _T	-	0.954	0.761	0.600	0.558	0.592	0.661	0.705	0.706	0.762
			F _L	0.92	0.92	0.92	0.92	0.92	0.92	0.92	0.92	0.92	0.92
4"	3-5/8 (92.1)	1-1/2 (38.1)	C _V	3.12	7.35	13.9	23.4	37.9	60.1	90.6	123	147	164
			X _T	0.676	0.551	0.524	0.488	0.449	0.443	0.463	0.509	0.569	0.674
			F _L	0.85	0.85	0.85	0.85	0.85	0.85	0.85	0.85	0.85	0.85
6"	5-3/8 (136.5)	2-1/2 (63.5)	C _V	3.9	13.3	23.1	36.2	63.0	105	156	217	280	319
			X _T	0.961	0.686	0.615	0.584	0.540	0.513	0.496	0.480	0.513	0.586
			F _L	0.82	0.82	0.82	0.82	0.82	0.82	0.82	0.82	0.82	0.82



Model
390 Control Valve

Table 7

Modified Equal Percent - Flow Down

Valve Size	Port Inches (mm)	Travel Inches (mm)	Coefficient	Percentage of Valve Travel									
				10%	20%	30%	40%	50%	60%	70%	80%	90%	100%
2"	1-7/8 (47.6)	1-1/2 (38.1)	C _V	-	2.28	7.52	15.7	24.1	31.6	38.2	43.5	46.7	48.7
			X _T	-	0.641	0.571	0.584	0.634	0.698	0.778	0.803	0.771	0.760
			F _L	0.93	0.93	0.93	0.93	0.93	0.93	0.93	0.93	0.93	0.93
3"	2-7/8 (73)	2 (50.8)	C _V	0.475	3.07	11.8	26.8	46.6	69.3	89.5	100	103	114
			X _T	0.949	0.712	0.55	0.604	0.682	0.697	0.706	0.762	0.856	0.771
			F _L	0.95	0.95	0.95	0.95	0.95	0.95	0.95	0.95	0.95	0.95
4"	3-5/8 (92.1)	2 (50.8)	C _V	4.33	11.3	23.3	45.0	79.6	121	155	176	192	202
			X _T	0.624	0.523	0.482	0.45	0.453	0.502	0.599	0.696	0.723	0.735
			F _L	0.89	0.89	0.89	0.89	0.89	0.89	0.89	0.89	0.89	0.89
6"	5-3/8 (136.5)	3 (76.2)	C _V	5.22	16.6	30.8	55.0	100	168	241	299	351	378
			X _T	0.883	0.725	0.571	0.597	0.592	0.514	0.526	0.623	0.667	0.717
			F _L	0.89	0.89	0.89	0.89	0.89	0.89	0.89	0.89	0.89	0.89

Table 8

Low-Noise 3 (A1) - Flow Up

Valve Size	Port Inches (mm)	Travel Inches (mm)	Coefficient	Percentage of Valve Travel									
				10%	20%	30%	40%	50%	60%	70%	80%	90%	100%
2"	1-7/8 (47.6)	1-1/2 (38.1)	C _V	3.00	7.70	13.0	17.8	22.3	26.4	31.0	35.3	39.0	42.0
			X _T	0.516	0.602	0.604	0.610	0.607	0.618	0.608	0.607	0.612	0.608
			F _L	0.80	0.80	0.80	0.80	0.80	0.80	0.80	0.80	0.80	0.80
3"	2-7/8 (73)	2 (50.8)	C _V	6.60	24.1	42.1	58.9	74.1	86.8	97.4	105	110	111
			X _T	0.727	0.610	0.560	0.558	0.588	0.641	0.687	0.723	0.738	0.772
			F _L	0.80	0.80	0.80	0.80	0.80	0.80	0.80	0.80	0.80	0.80
4"	3-5/8 (92.1)	2 (50.8)	C _V	7.56	27.3	50.1	71.5	90.8	109	126	142	155	162
			X _T	0.625	0.586	0.545	0.519	0.520	0.542	0.577	0.614	0.640	0.674
			F _L	0.80	0.80	0.80	0.80	0.80	0.80	0.80	0.80	0.80	0.80
6"	5-3/8 (136.5)	3 (76.2)	C _V	28.6	66.4	103	142	180	220	253	284	308	324
			X _T	0.423	0.513	0.533	0.525	0.557	0.535	0.543	0.560	0.598	0.627
			F _L	0.80	0.80	0.80	0.80	0.80	0.80	0.80	0.80	0.80	0.80

NOTE: For other noise reduction levels consult Dyna-Flo.

For quick opening valve characteristics please contact Dyna-Flo

Relationships of Note:

$$C_1 = 39.76 \sqrt{X_T}$$

$$C_G = C_V C_1$$

$$K_M = F_L^2$$

! NOTE ! - Modified Equal Percent is a factor of travel and requires no special trim options above Equal Percent.



Model 390 Control Valve

Table 9

Models 390 Valve Sizing Coefficients Two Stage Anti-Cavitation - Flow Down

Valve Size	Port Inches (mm)	Travel Inches (mm)	Coefficient	Percentage of Valve Travel									
				10%	20%	30%	40%	50%	60%	70%	80%	90%	100%
2"	1-3/4 (44.5)	2 (50.8)	C _v	1.07	1.97	3.29	4.86	6.58	8.36	10.1	11.7	13.0	14.0
			F _L	0.98	0.98	0.98	0.98	0.98	0.98	0.98	0.98	0.98	0.98
3"	2-1/2 (63.5)	2-1/2 (63.5)	C _v	1.46	4.98	9.24	13.2	17.0	20.7	24.7	28.5	31.9	34.4
			F _L	0.98	0.98	0.98	0.98	0.98	0.98	0.98	0.98	0.98	0.98
4"	3-7/16 (87.3)	3 (76.2)	C _v	2.61	9.01	15.6	21.8	28.3	34.8	40.4	46.4	52.2	58.0
			F _L	0.98	0.98	0.98	0.98	0.98	0.98	0.98	0.98	0.98	0.98
6"	5-1/4 (133.4)	4 (101.6)	C _v	7.50	20.7	33.8	47.0	60.1	73.3	87.0	100	112	123
			F _L	0.98	0.98	0.98	0.98	0.98	0.98	0.98	0.98	0.98	0.98

Minimum Throttling C _v ²	Valve Size	2 inch	3 inch	4 inch	6 inch
		0.580	0.720	0.900	1.72

- 1 The 2 inch three stage anti-cavitation valves have unbalanced plugs, these valves are of a Model 392 valve design.
- 2 Valves should not be throttled at a Cv less than the specified minimum throttling Cv for extended periods of time, erosion damage to valve trim may occur.

NOTE: All F_L values are at 100% travel.

Models 390 Valve Sizing Coefficients Three Stage Anti-Cavitation - Flow Down

Valve Size	Port Inches (mm)	Travel Inches (mm)	Coefficient	Percentage of Valve Travel									
				10%	20%	30%	40%	50%	60%	70%	80%	90%	100%
2" ¹	1 (25.4) ¹	2 (50.8)	C _v	0.272	1.10	1.98	2.80	3.63	4.46	5.30	6.07	6.61	6.73
			F _L	0.99	0.99	0.99	0.99	0.99	0.99	0.99	0.99	0.99	0.99
3"	1-7/8 (47.6)	2-1/2 (63.5)	C _v	0.747	20.0	3.92	6.15	8.00	9.50	11.0	12.8	14.9	16.5
			F _L	0.99	0.99	0.99	0.99	0.99	0.99	0.99	0.99	0.99	0.99
4"	2-7/8 (73)	3 (76.2)	C _v	2.80	5.50	8.30	11.0	13.9	16.7	19.4	22.2	25.0	27.8
			F _L	0.99	0.99	0.99	0.99	0.99	0.99	0.99	0.99	0.99	0.99
6"	4-9/16 (115.9)	4 (101.6)	C _v	6.10	13.2	19.8	26.1	34.1	41.5	48.2	54.5	60.9	65.0
			F _L	0.99	0.99	0.99	0.99	0.99	0.99	0.99	0.99	0.99	0.99

Minimum Throttling C _v ²	Valve Size	2 inch	3 inch	4 inch	6 inch
		0.590	1.20	1.70	3.10

- 1 The 2 inch three stage anti-cavitation valves have unbalanced plugs, these valves are of a Model 392 valve design.
- 2 Valves should not be throttled at a Cv less than the specified minimum throttling Cv for extended periods of time, erosion damage to valve trim may occur.

NOTE: All F_L values are at 100% travel.

For Relationships of Note See Page 7.



Model
390 Control Valve

Table 10

Typical Construction Materials

Key	Part Description	Standard Construction	CF8M Construction
1	BODY	ASTM (SA352 LCC), ASTM (A215 WCC)	ASTM (SA351 CF8M)
2	BONNET	ASTM (SA352 LCC), ASTM (A215 WCC)	ASTM (SA351 CF8M)
3	PACKING BOX RING	S31600	S31600
4	PACKING SPRING	S30400	-
5	LANTERN RING	-	S31600
6	RETAINING RING	S30200	S30200
7	SPECIAL WASHER	S30400	-
8	V-RING PACKING SET	PTFE	PTFE (Double)
9	PACKING FOLLOWER	S31600	S31600
10	STEM WIPER	FELT	FELT
11	CAGE	S17400	S31600 / ENC
12	VALVE PLUG / STEM ASS'Y	S41600 PLUG/ S20910 STEM	S31600 with CoCr-A SEAT & GUIDE S20910 Stem
13	SEAT RING	S41600	S31600-CoCr-A
14	SEAL RING	CARBON / PTFE / R30003	CARBON / PTFE / R30003
15	BACKUP RING	S31600	S31600
16	PACKING FLANGE	CARBON STEEL-PLATED	CARBON STEEL-PLATED
17	PACKING NUT	SA-194 2H	8M
18	PACKING STUD	SA-193 B7	SA-194 B8M
19	BONNET STUD	SA-193 B7	SA-194 B8M
20	BONNET NUT	SA-194 2H	8M
21	SEAT RING GASKET	N06600 / GRAPHITE	N06600 / GRAPHITE
22	BONNET GASKET	N06600 / GRAPHITE	N06600 / GRAPHITE

Key	Part Description	NACE Construction (2002)
1	BODY	ASTM (SA352 LCC), ASTM (A215 WCC)
2	BONNET	ASTM (SA352 LCC), ASTM (A215 WCC)
3	PACKING BOX RING	S31600
5	LANTERN RING	S31600
6	RETAINING RING	S30200
8	V-RING PACKING SET	PTFE (Double)
9	PACKING FOLLOWER	S31600
10	STEM WIPER	FELT
11	CAGE	S17400 DH1150
12	VALVE PLUG / STEM ASS'Y	S31600 with CoCr-A SEAT & GUIDE S20910 Stem
13	SEAT RING	S31600-CoCr-A
14	SEAL RING	CARBON / PTFE / R30003
15	BACKUP RING	S31600
16	PACKING FLANGE	CARBON STEEL-PLATED
17	PACKING NUT	SA-194 2H
18	PACKING STUD	SA-193 B7
19	BONNET STUD	SA-193 B7M
20	BONNET NUT	SA-194 2HM
21	SEAT RING GASKET	N06600 / GRAPHITE
22	BONNET GASKET	N06600 / GRAPHITE



Model
390 Control Valve

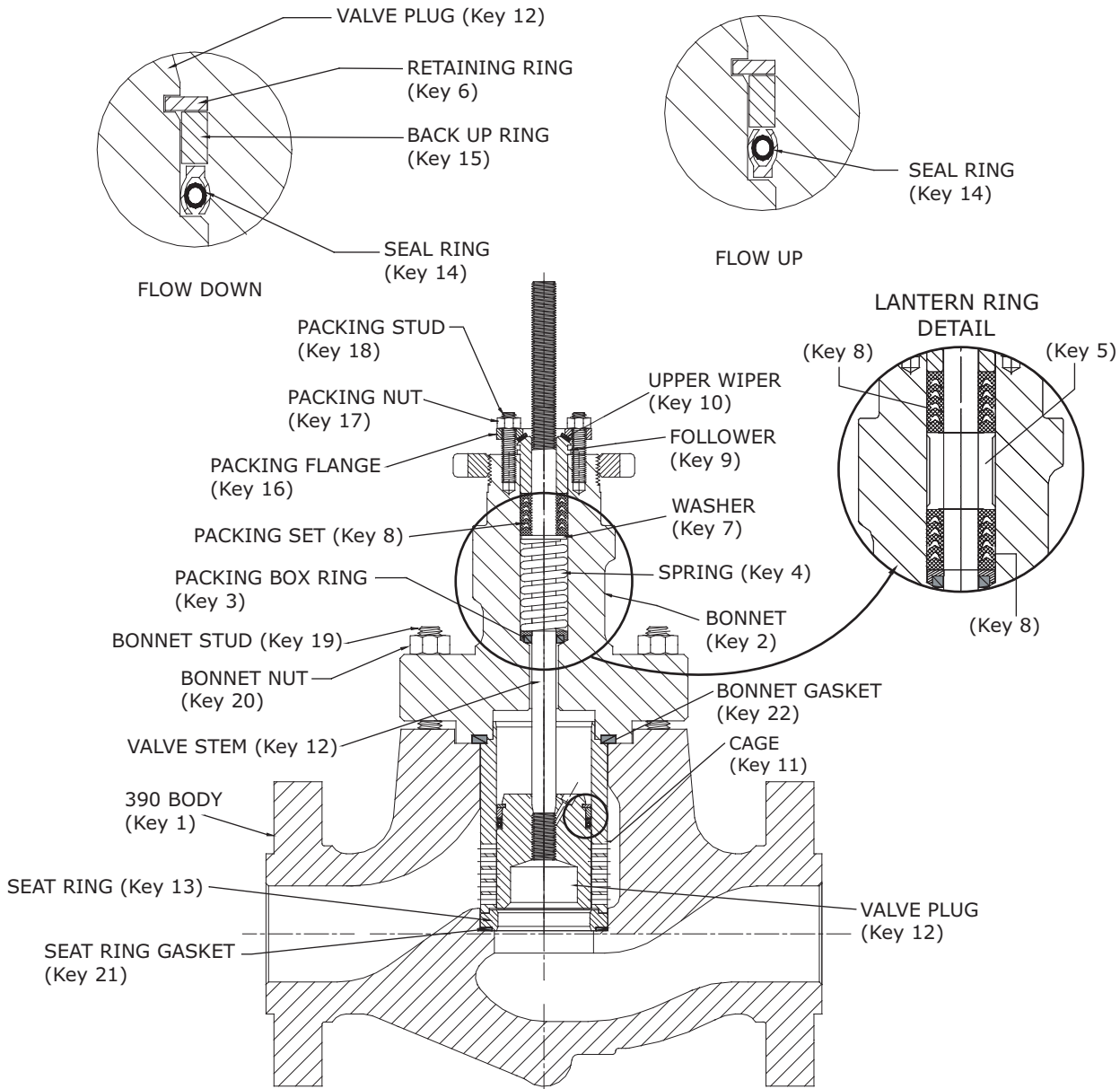
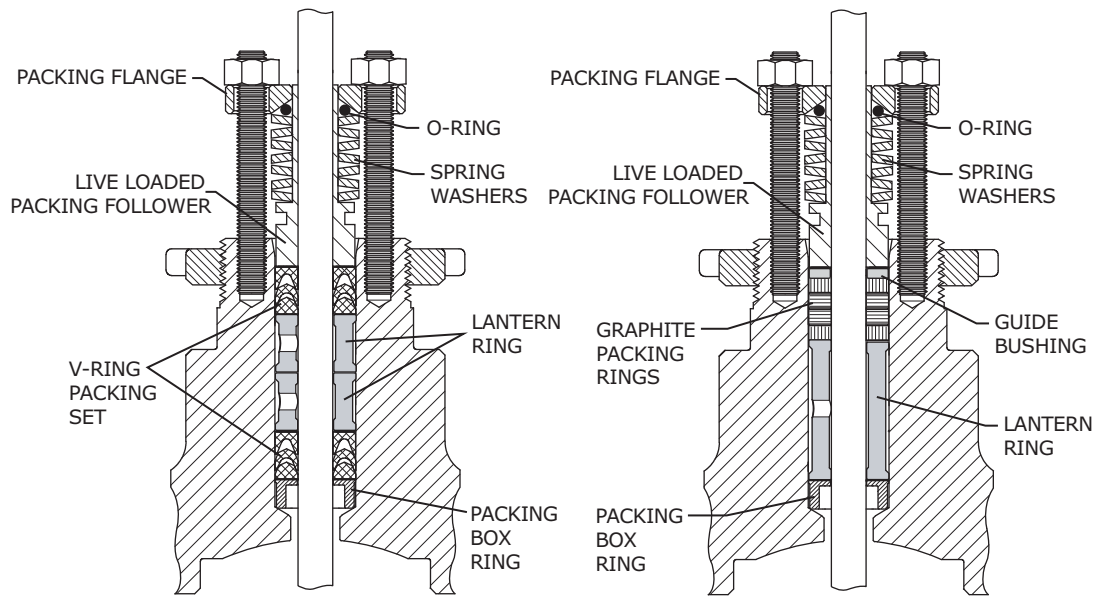

Figure 3 Cross-section of 390 Series Control Valve



Model
390 Control Valve



TYPICAL LIVE LOADED PACKING WITH PTFE V-RING PACKING SETS

TYPICAL LIVE LOADED PACKING WITH GRAPHITE PACKING RINGS

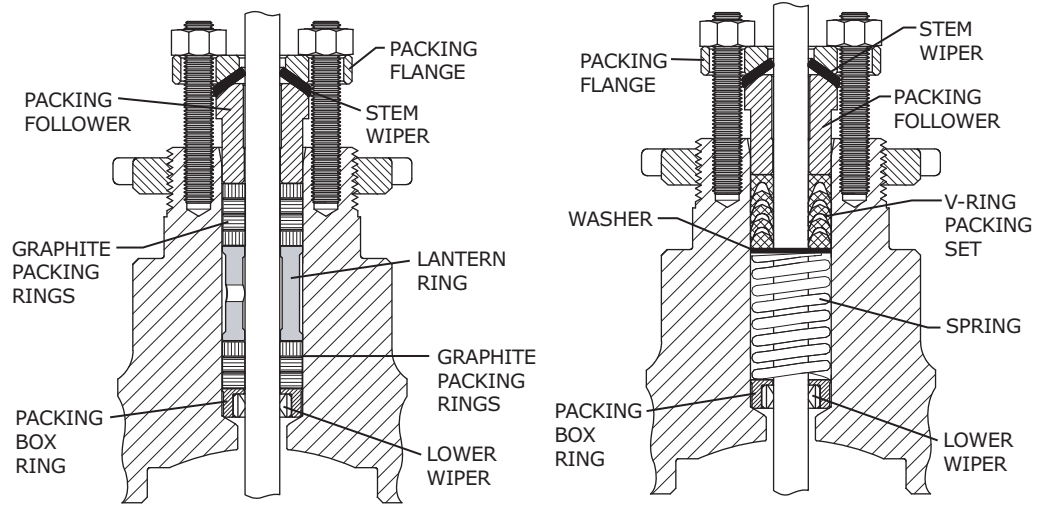

STANDARD HIGH TEMPERATURE PACKING DIAGRAM

STANDARD SINGLE PTFE PACKING DIAGRAM

Figure 4 Typical Packing Arrangements



Model
390 Control Valve

Table 11

Fail Open Actuator
Shut Off Capabilities for Model 390
Metal Seat, Class IV Control Valve
35 psig supply pressure

Valve Size (inch)	Actuator Size Pressure Drop Psig (kPag)				
	DFO - 2105	DFO - 2156	DFO - 3105	DFO - 3156	DFO - 3220
2"	3750 (25,855) ¹	3750 (25,855) ¹	—	—	—
3"	3750 (25,855) ²	3750 (25,855) ¹	3750 (25,855) ²	3750 (25,855) ¹	—
4"	—	—	—	3750 (25,855) ³	3750 (25,855) ¹
6"	—	—	—	—	2280 (15,720) ⁴

Note

- 1 - 6 to 26 Psig bench range
- 2 - 6 to 24 Psig bench range
- 3 - 6 to 22 Psig bench range
- 4 - 6 to 17 Psig bench range

Table 12

Fail Closed Actuator
Shut Off Capabilities for Model 390
Metal Seat, Class IV Control Valve
35 psig supply pressure

Valve Size (inch)	Actuator Size Pressure Drop Psig (kPag)				
	DFC - 2105	DFC - 2156	DFC - 3105	DFC - 3156	DFC - 3220
2"	3750 (25,855) ¹	3750 (25,855) ¹	—	—	—
3"	3750 (25,855) ²	3750 (25,855) ¹	3750 (25,855) ²	3750 (25,855) ¹	—
4"	—	—	—	2280 (15,720) ²	3750 (25,855) ³
6"	—	—	—	—	2280 (15,720) ⁴

Note

- 1 - 6 to 30 psig Bench Range
- 2 - 9 to 30 psig Bench Range
- 3 - 15 to 30 psig Bench Range
- 4 - 18 to 30 Psig Bench Range with a DFC4-3220 Actuator



Model
390 Control Valve

Table 13

Port Diameters, Valve Plug Travel and Yoke Boss Diameter

Valve Size Inch	Port Diameter Inch (mm)	Max Valve Travel Inch (mm)	Yoke Boss Diameter Inch (mm)	
			Stem	Valve
2" Linear, Mod. Equal Percent & Low-Noise	1 7/8 (47.6)	1-1/2 (38.1)	1/2 (12.7)	2-13/16 (71.4)
			3/4 (19.1)	3-9/16 (90.5)
2" Equal Percent	1-7/8 (47.6)	1-1/8 (28.6)	1/2 (12.7)	2-13/16 (71.4)
			3/4 (19.1)	3-9/16 (90.5)
2" Anti-Cavitation Stage 2	1-3/4 (44.5)	2 (50.8)	1/2 (12.7)	2-13/16 (71.4)
			3/4 (19.1)	3-9/16 (90.5)
2" Anti-Cavitation Stage 3	1 (25.4)	2 (50.8)	3/4 (19.1)	3-9/16 (90.5)
3" Linear, Mod. Equal Percent & Low-Noise	2-7/8 (73)	2 (50.8)	1/2 (12.7)	2-13/16 (71.4)
			3/4 (19.1)	3-9/16 (90.5)
			1 (25.4)	5 (127)
3" Equal Percent	2-7/8 (73)	1-1/2 (38.1)	1/2 (12.7)	2-13/16 (71.4)
			3/4 (19.1)	3-9/16 (90.5)
			1 (25.4)	5 (127)
3" Anti-Cavitation Stage 2	2-1/2 (63.5)	2-1/2 (63.5)	1/2 (12.7)	2-13/16 (71.4)
			3/4 (19.1)	3-9/16 (90.5)
			1 (25.4)	5 (127)
3" Anti-Cavitation Stage 3	1-7/8 (47.6)	2-1/2 (63.5)	1/2 (12.7)	2-13/16 (71.4)
			3/4 (19.1)	3-9/16 (90.5)
			1 (25.4)	5 (127)
4" Linear, Mod. Equal Percent & Low-Noise	3-5/8 (98)	2 (50.8)	3/4 (19.1)	3-9/16 (90.5)
			1 (25.4)	5 (127)
4" Equal Percent	3-5/8 (92.1)	1-1/2 (38.1)	3/4 (19.1)	3-9/16 (90.5)
			1 (25.4)	5 (127)
4" Anti-Cavitation Stage 2	3-7/16 (87.3)	3 (76.2)	3/4 (19.1)	3-9/16 (90.5)
			1 (25.4)	5 (127)
4" Anti-Cavitation Stage 3	2-7/8 (73)	3 (76.2)	3/4 (19.1)	3-9/16 (90.5)
			1 (25.4)	5 (127)
6" Linear, Mod. Equal Percent & Low-Noise	5-3/8 (136.5)	3 (76.2)	3/4 (19.1)	3-9/16 (90.5)
			1 (25.4)	5 (127)
			1-1/4 (31.8)	5 (127)
6" Equal Percent	5-3/8 (136.5)	2-1/2 (63.5)	3/4 (19.1)	3-9/16 (90.5)
			1 (25.4)	5 (127)
			1-1/4 (31.8)	5 (127)
6" Anti-Cavitation Stage 2	5-1/4 (133.4)	4 (101.6)	3/4 (19.1)	3-9/16 (90.5)
			1 (25.4)	5 (127)
			1-1/4 (31.8)	5 (127)
6" Anti-Cavitation Stage 3	4-9/16 (115.9)	4 (101.6)	3/4 (19.1)	3-9/16 (90.5)
			1 (25.4)	5 (127)
			1-1/4 (31.8)	5 (127)



Model 390 Control Valve

Table 14

Common Trim Options and Temperature Ratings

Trim ⁴ Spec	Valve Plug	Stem	Cage	Seat Ring	Minimum ³ Temperature	Maximum Temperature
					°F (°C)	°F (°C)
S	S41600	S20910	S17400 PH	S41600	-20 (-29)	650 (343) ¹
N	S31600 / CoCr-A Seat and Guide	S20910	S17400 PH DHT	S31600 / CoCr-A	-50 (-46)	650 (343)
C	S31600 / CoCr-A Seat and Guide	S20910	S31600 ENC	S31600 / CoCr-A	-50 (-46) ²	750 (399) ²

- 1 Maximum temperature limited by body material (LCC body temperature limitation shown).
- 2 Check body material temperature limitations.
- 3 Temperatures need to be considered when specifying trim materials for elevated temperatures in corrosive environments, consult factory for further information.
- 4 Trim Spec relates to Model Numbering System on Page 12.

NOTE: Bonnet Bolting refer to Table 14.

Table 15

Valve Bolting Temperature Limitations

Stud Material	Temperature Limitation
B7	-50°F to 900°F (-46°C TO 482°C)
B7M	-50°F TO 900°F (-46°C TO 482°C)
B8M	-325°F TO 1500°F (-198°C TO 816°C)
S17400 DH 1150	-50°F TO 650°F (-46°C TO 343°C)
Nut Material	Temperature Limitation
2H, 2HM & 8M	Not Limiting Factors

Table 16

Materials and Temperature Limits for Parts other than Valve Body and Trim

Part	Material	Minimum Temperature	Maximum Temperature
Backup Ring	S31600	-325°F (198°C)	1100°F (593°C)
Retaining Ring	S30200	-425°F (-254°C)	1100°F (593°C)
Seal Ring	PTFE with R30003 Spring	-100°F (-73°C)	450°F (232°C)
Bonnet / Cage Gasket	N06600 / Graphite	-400°F (-240°C)	800°F (427°C)
Seat Ring Gasket	N06600 / Graphite	-400°F (-240°C)	800°F (427°C)
Packing	PTFE V-Ring	-40°F (-40°C)	450°F (232°C)
	Graphite Ribbon / Filament	-425°F (-254°C)	1000°F (537°C)
Body to Bonnet Studs (NACE-2002)	B7M (LCC Body)	-50°F (-46°C)	700°F (371°C)
Body to Bonnet Nuts (NACE-2002)	2HM (LCC Body)	-50°F (-46°C)	700°F (371°C)

For NACE 2003 body to bonnet studs and nuts please contact Dyna-Flo



Model 390 Control Valve

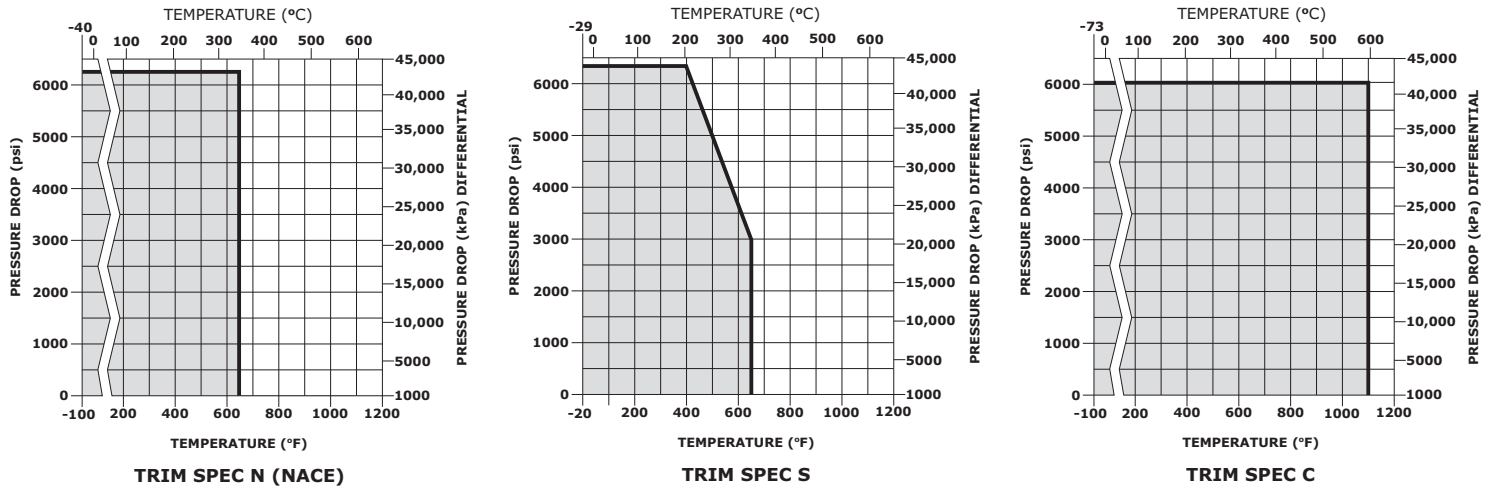

Figure 5 Trim Material Pressure / Temperature Limitations

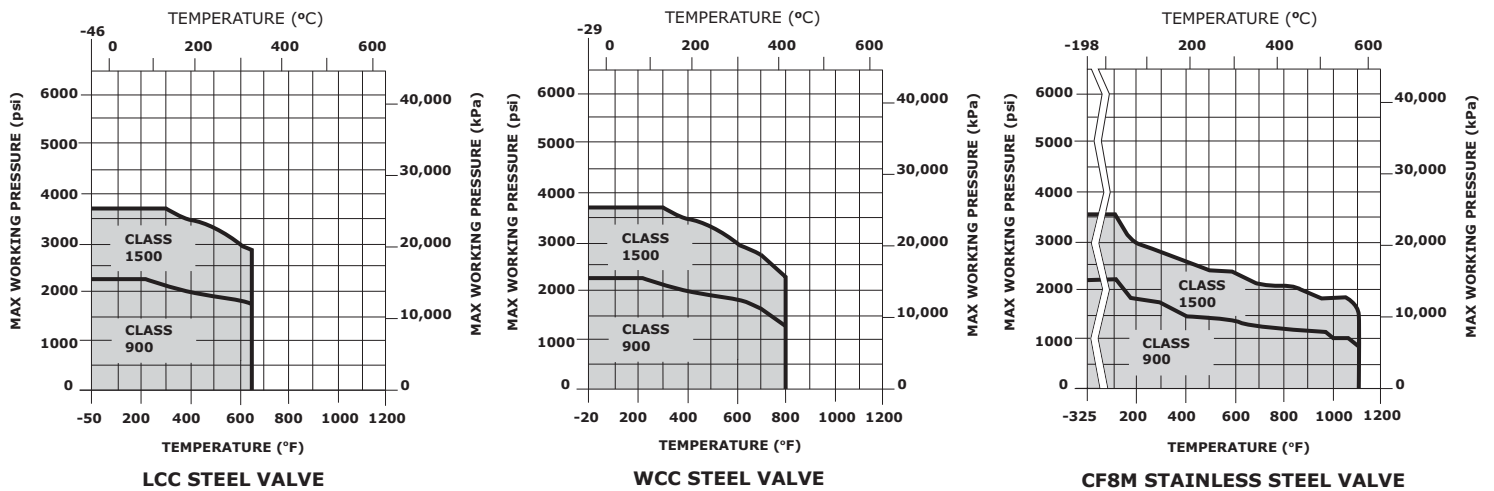

Figure 6 Pressure / Temperature Charts as per ASME B16.34



Model **390** Control Valve

Ordering Guide

Dyna-Flo Model 390 Control Valve | Model Numbering System

Sample Part Number

390-3AJ-L2S-EP

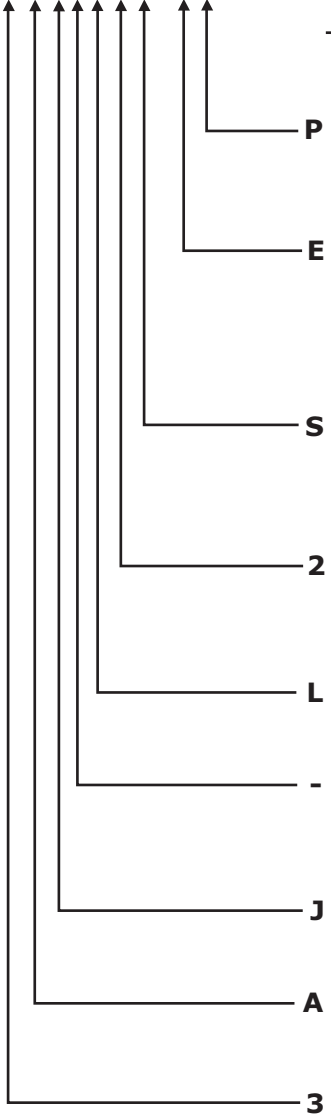

Code	Description
Packing Style	
P	Spring Loaded PTFE V-Ring
D	Double PTFE V-Ring
G	Graphite High Temp
T	Live Loaded (PTFE)
L	Live Loaded (Graphite)
Characteristic	
L	Linear
E	Equal Percent
M	Modified Equal Percent
H	Low-Noise 3
2	Anti-Cavitation 2 Stage
3	Anti-Cavitation 3 Stage
Trim	
S	Standard
N	NACE / Low Temp
C	CF8M Construction
Bonnet (Standard and Extension)	
2	2-13/16" (71.4 mm) Std.
5	5" (127 mm) Std.
B	3-9/16" (90.5 mm) Ext.
3	3-9/16" (90.5 mm) Std.
A	2-13/16" (71.4 mm) Ext.
C	5" (127 mm) Ext.
Body Material	
L	LCC
W	WCC
M	CF8M
Bolting	
-	B7 / 2H (Standard)
B	B8M / 8M
A	B7M / 2HM
C	S17400 DH 1150 / 2HM
Connection Style	
F	RF
J	RTJ
ASME Rating	
A	900
B	1500
C	900/1500
Valve Size	
2	2 inch
3	3 inch
4	4 inch
6	6 inch

! NOTE ! - Modified Equal Percent is a factor of travel and requires no special parts or trim options that differ from Equal Percent.

Our Commitment of Quality

Dyna-Flo is committed to continuous improvement. All efforts have been taken to maximize the accuracy of this information. Without notification, product specifications and designs may be modified at any time. The issue of this document is for information only, and does not imply suitability, a warranty, or guarantee for a specific service.