



Model
DF2000 Control Valve
Operation, Parts and Instruction Manuals



Figure 1 *DF2000 Control Valve & DFC Actuator*

Dyna-Flo DF2000

Operation, Parts and Instruction Manual

Table of Contents

Introduction	2	Lapping	8
Specifications	3	Seat Leakage	9
Inlet Pressure Table	3	Torque Value Table	9
Port, Yoke Boss Diameter, Stem Diameter and Rated Travel	4	Valve Diagram & Key Numbers	10
Unpacking	4	Parts List & Materials	11
Installation	4	Parts Kits	12
Periodic Inspection	5		
Maintenance	6		
Body Assembly	6		
Bonnet Removal	6		
Seat Ring Removal	6		
Packing Box	6		
Packing Types	7		
Body Reassembly	7		



Model
DF2000 Control Valve
Operation, Parts and Instruction Manuals

!NOTICE!

These instructions are meant to be used with the Dyna-Flo 2000 Technical (Sales) Bulletin. If you do not have the Technical Bulletin, contact Dyna-Flo immediately, or visit www.dynaflo.com

Each valve is factory tested to insure compliance with ASME B16.34 shell testing and FCI 70-2 seat leakage criteria.

Introduction

The Model DF2000 Control Valves are heavy duty globe style control valves used in all kinds of demanding oil and gas applications, from well head to gas plant and beyond.

The Model DF2000 control valves are post guided, single port valves that can be used for either throttling or on-off control of either liquids or gasses.

The actuator for the Model DF2000 valve is typically a Dyna-Flo model DFC or DFO linear actuator. These heavy duty actuators are spring return diaphragm style, and can be used with or without a valve positioner.

The Model DF2000 control valves are manufactured to a high level of quality specifications to ensure superior performance and customer satisfaction.

General

The following instructions are to be thoroughly reviewed and understood prior to installing, operating or performing maintenance on this equipment. Work on this equipment should be done by experienced personnel. Throughout the manual, safety and caution notes appear and must be strictly followed to prevent serious injury or equipment malfunction.

Scope

The valve configuration and construction materials were selected to meet particular pressure, pressure drop, temperature, and process fluid conditions. Some body and trim material combinations are limited in their pressure and temperature ranges. Do not apply any other conditions to the valve without first contacting your Dyna-Flo sales office.

This manual is written to be a practical and useful guide to successfully using the Dyna-Flo DF2000 for many years.

! CAUTION !

To avoid personal injury or installation damage as a result of the sudden release of process pressure or the breaking of parts, do not install the valve assembly where service conditions could exceed the limits stated in this manual or on the equipment nameplates. Use government codes, accepted industry standards and good piping practices to select pressure-relieving equipment for protection of your installation. It is also important to wear the proper protective equipment when performing any installation or maintenance activity.



Model
DF2000 Control Valve
 Operation, Parts and Instruction Manuals

Table 1

Rated Inlet Pressure and Temperature

Valve Size	Body Type	Class [◇]	Temperature		Maximum Pressure		
			°F	°C	Psi	kPa	
1 and 2 Inch	NPT	3750* (1500 ANSI)	100	38	3750	25,855	
			450	232	3425	23,615	
		6250* (2500 ANSI)	100	38	6250	43,092	
			450	232	5710	39,369	
		Flanged	600 ANSI	100	38	1500	10,342
				450	232	1370	9,446
	1500 ANSI		100	38	3750	25,855	
			450	232	3425	23,615	
	2500 ANSI	100	38	6250	43,092		
		450	232	5710	39,369		

* Indicates Working Class Pressure (Psig)

◇ Indicates Class or Cold Working Pressure Limit

Specifications

Valve Size, Flange Ratings, and Connections

Size: 1" and 2"
 Rating: ANSI 150/300/600/900/1500/2500
 Connections: RF / RTJ / NPT

Rated Inlet Pressure and Temperature

Per ANSI / ASME B16.34 - 1996
 Also see Table 1

Maximum Allowable Pressure Drops

Flow-to-open: Capable of full rated pressure drops
 Flow-to-close: For more information contact your Dyna-Flo Sales Office

(See Tables 7 & 8 of Sales Bulletin)

Material Temperature Capabilities

-50 to 450°F (-45 to 232°C) for standard LCC body.

Construction Materials

See Figure 4 for valve diagram and keys
 See Parts List for construction materials

Dimensions

Valve and Actuator assembly diagram - See figure 4
 Valve and Actuator assembly dimensions - See tables 9 and 10 of Sales Bulletin

Flow Direction

Up through seat ring and out past valve plug

Flow Characteristic

Equal Percentage, others available upon request.

Port, Yoke Boss Diameter, Stem Diameters, and Rated Travel

See Table 5 of Sales Bulletin

Valve Sizing Coefficients

Maximums by port size (Cv)

1/4"	1.64
3/8"	4.03
1/2"	6.82
3/4"	14.00
1"	23.70
1-1/4"	34.50

Detailed - See Table 3 of Sales Bulletin

Sizing Coefficients

See Sales Bulletin for:
 Fail Close Actuator - See Table 7
 Fail Open Actuator - See Table 8

Valve Body and Actuator
 Approximate Weights - See Table 6 of Sales Bulletin

Options

- Trim in Tungsten Carbide
- Anti-corrosion coating of internal body passage
- Live loaded low emission packing

For more information and other options contact your Dyna-Flo sales office.



Model
DF2000 Control Valve
 Operation, Parts and Instruction Manuals

Table 2

Model DF2000

Port Size, Yoke Boss Diameter, Stem Diameters, and Rated Travel In. (mm)

Valve Size	Port Diameter	Standard (inch / mm)			Optional (inch / mm)		
		Yoke Boss Diameter	Stem Diameter	Rated Travel	Yoke Boss Diameter	Stem Diameter	Rated Travel
1 Inch	1/4 (6.4)	2-1/8 (54)	3/8 (9.5)	3/4 (9.5)	2-13/16 (71)	1/2 (12.7)	3/4 (19)
	3/8 (9.5)						
	1/2 (12.7)						
	3/4 (19.1)						
2 Inch	1/4 (6.4)	2-13/16 (71)	1/2 (12.7)	3/4 (19)	3-9/16 (90)	3/4 (19)	3/4 (19)
	3/8 (9.5)						
	1/2 (12.7)						
	3/4 (19.1)						
	1 (25.4)						
1-1/4 (31.8)							

Unpacking Valve from Shipping Container

Check the packing list against materials received, while unpacking the valve. The Packing List describes valve and accessories in each shipping container.

When lifting the valve from shipping container, it is advisable to remove 2 actuator casing bolts, 180° apart, and temporarily replace them with eye bolts and nuts. Position the lifting straps through the eye bolts to avoid damage to the tubing and mounted accessories.

Installation

Before installing the valve, clean dirt, welding chips, scale or other foreign material from the line.

Look for signs of gasket leakage through the line flanges. Make repairs, if required.

Check packing box bolting for proper tightness, stem leakage may be prevented by tightening the packing nuts. Reference Table 3 for packing nut torque specifications.

Packing Maintenance:

! CAUTION !

Do not over tighten packing! This can cause excessive packing wear and high stem friction that may impede movement!

If the packing is leaking and tightening the packing flange does not stop the leak then it is recommended that you remove the valve from the line.



Model **DF2000** Control Valve Operation, Parts and Instruction Manuals

Installation

(cont'd)

- 1 Install the valve with flow through the valve in the direction as indicated by the arrow cast on the valve body. The valve assembly may be installed in any position unless limited by vibration considerations.

! NOTE !

The normal method of installation is with the actuator in vertical position above the valve body. In some non-vertical applications the actuator may need to be supported.

! WARNING !

Keep hands, hair and clothing away from all moving parts when operating the valve! Serious injury can result from failure to do so!

- 2 When possible, stroke the valve and check for smooth operation through the full-stroke. Unsteady valve stem movement could be an indication of an internal problem.

Air Piping

The actuators are designed to accept 1/4" NPT connection. Use 3/8" OD tubing (or equivalent) for all air lines. All connections must be free of leaks.

! CAUTION !

Do not exceed supply pressure indicated on serial plate located on the yoke of the actuator.

Periodic Inspection

! CAUTION !

Use safe work practices and lock out procedures when isolating valves and actuators! Always be aware of flammable instrument gas!

- 1 Avoid personal injury from sudden release of process pressure! Before performing any maintenance operation:
 - a Disconnect any power supply media lines providing air / gas pressure, electric power, or a control signal to the actuator. Ensure the actuator cannot suddenly operate the valve.
 - b Isolate the valve from process pressure with bypass valves or completely shut off the process. Relieve process pressure, and drain the process fluid from the up and down stream of the valve.
 - c Vent the pneumatic actuator loading pressure and relieve any actuator spring preload.
 - d Use Safety lock-out procedures to be sure that the above provisions stay in effect while you complete the work on your equipment.
- 2 Check for process fluid leakage to the atmosphere through the body to bonnet joint and (if equipped) any NPT connection.
- 3 Examine the valve for damage caused by corrosive fumes or process drippings.
- 4 Clean the valve and repaint areas of severe oxidation.
- 5 Make sure positioner linkage (if equipped) and stem clamp are securely fastened. If the stem clamp is loose, check plug thread engagement and retighten. Refer to the Dyna-Flo Model DFC, or DFO Manual for detailed instructions.
- 6 Ensure all accessories, mounting brackets and fasteners are secure.
- 7 Clean any dirt and foreign material from the plug stem.



Model **DF2000** Control Valve Operation, Parts and Instruction Manuals

Maintenance

Body Disassembly

- 1 Vent the pneumatic actuator loading pressure and relieve any actuator spring preload.

! CAUTION !

The body can be serviced in-line, after all process pressure and fluid are released. Remove if convenient. If the valve is to be serviced out of line, it is important that the body be firmly held in a clamping device. Serious injury can result from failure to do so!

- 2 Once the body is secured, and any actuator spring preload relieved, remove the stem connector (Key 18) joining the valve stem to the actuator stem.

ALL Key references to follow are from Figure 4.

- 3 With a hammer and heavy chisel, strike the actuator yoke lock nut (Key 14) in a counter clockwise direction to loosen it, and remove the actuator. Actuator removal may require a second person, or the use of a hoist.

Bonnet Removal and Inspection

- 1 Remove the packing nuts (Key 12), note any corrosion or roughness in the threads.
- 2 Remove the packing flange (Key 10). Note any corrosion and remove the stem wiper (Key 11) and packing follower (Key 9).
- 3 DF2000 bonnets are factory tightened as show in Table 3. A large pipe wrench is commonly used to remove the bonnet. Once the bonnet is loosened it should move freely by hand. If the bonnet does not move freely be cautious of a build up of process pressure. Once the bonnet is disengaged from the body, carefully remove with the plug and stem still attached.
- 4 Inspect the bonnet threads in the body for damage. Minor galling, or corrosion may require sandblasting.
- 5 The bonnet gasket (Key 3) may come out with the bonnet assembly. If not, carefully remove the bonnet gasket from the body, avoid scratching the gasket surface.

Seat Ring Removal and Inspection

- 1 A 1-3/8" deep socket (non-impact type) with a 3/4" drive (for the 1" valve) and a 1-13/16" deep socket (non-impact type) with a 3/4" drive (for the 2" valve) are required. A standard mechanic's "Pick Set" will help with the seat ring gasket removal (Key 15).
- 2 Wipe the gasket sealing surface of the body and the bonnet and inspect for signs of leakage, corrosion, or other marks. Refer to the section on wear limits for guidance if a concern arises.
- 3 Inspect the seat ring threads in the body for damage. Major galling, or corrosion may require sandblasting of the body to restore "as new" condition. Also, inspect the threads on the seat ring for signs of galling or corrosion.
- 4 Inspect the plug seating area, and the gasket surface of the seat ring for damage or marks of any kind. Deep marks are cause for replacement as the hard faced seat ring is difficult to recondition outside of the factory.

Packing Box

- 1 With the bonnet removed from the body, pull the plug and stem assembly (Key 17) out of the bonnet (Key 2). The plug and stem assembly can then be reinserted to push the packing [packing box ring (Key 5), the bottom packing set (Key 6), packing spacer (Key 7), and the top packing set (Key 8)] out of the packing box.
- 2 Retain the packing box ring, and spacer for use in the reassembly of the valve.
- 3 With all the parts removed from the bonnet, clean and inspect all gasket and packing seating surfaces. Also, inspect bushing (Key 2a) for damage. Check threads for galling or corrosion.



Model
DF2000 Control Valve
Operation, Parts and Instruction Manuals

Maintenance

(cont'd)

Packing Types

The DF2000 is standard equipped with jam style packing, as shown in Figure 2.

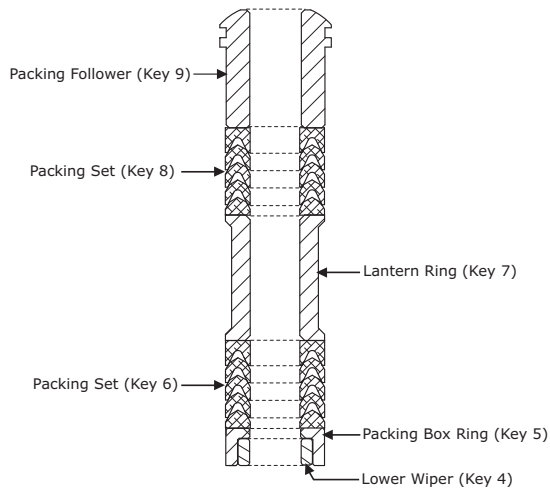

* Key Numbers Correspond to Figure 4 Keys

Figure 2 Jam Style Packing

Body Reassembly

Seat Ring Installation

- 1 Clean and inspect the seat ring threads, and the threads in the body. A 1-3/8" deep socket (non-impact) with a 3/4" drive (for the 1" valve) and a 1-13/16" deep socket (non-impact) with a 3/4" drive (for the 2" valve) is required for seat ring (Key 16) installation. Coat both sides of the seat ring gasket (Key 15) with Nickel based anti-seize compound, and place the gasket carefully in the body. Completely coat the seat ring threads with Nickel based anti-seize compound, and place the seat ring into a clean body. Dry threads could prevent proper seating of the seat ring against the gasket, allowing leakage.

- 2 Carefully use the deep socket and drive bar to thread the seat ring into place. The seat ring should turn smoothly into place. Any significant resistance should be investigated, and corrected to ensure proper assembly. Torque the seat ring as per torque values stated in Table 3.

Packing Box

- 1 Prepare the components for reassembling the packing box by using the appropriate packing lubricant (suggested lubricant: Dow Corning 111™) on the lower wiper (Key 4) for the bottom of the packing box ring (Key 5). Carefully place the assembled packing box ring (Key 4 & 5) in place, in the bottom of a clean packing box.
- 2 Lubricate the "V" of each PTFE packing ring (Key 6) and stack in a set as shown in Figure 2. There will be 2 sets of packing rings.
- 3 Insert the bottom packing set with the open end of the "V" pointing down, over the valve stem. Avoid sliding the packing over any sharp edges that could damage the packing. Insert the packing spacer (Key 7), and then the top set of packing (Key 8) with the "V" again pointing down.

Bonnet Installation

- 1 Coat the large diameter guide section of the valve plug and stem assembly (Key 17) with mechanical assembly grease, and carefully place the plug into the seat ring (Key 16).
- 2 Coat both sides of the bonnet gasket (Key 3) and bonnet threads with Nickel based anti-seize compound, and place the gasket carefully in a clean body.
- 3 Lower the bonnet (Key 2) carefully over the stem and hand tighten into place.
- 4 Torque the bonnet to the valve size appropriate to the torque value listed in Table 3.



Model **DF2000** Control Valve Operation, Parts and Instruction Manuals

Maintenance

(cont'd)

Packing Box (Cont'd)

- 4** Insert the packing follower (Key 9) over the stem, into the packing box. Slide the stem wiper (Key 11) over the stem, down to the top of the packing follower (Key 9).
- 5** Place the packing flange (Key 10) over the studs (Key 13) and stem, with the beveled stem hole side facing the packing follower (Key 9).
- 6** Lubricate the exposed portion of the packing flange stud (Key 13) with Nickel based anti-seize compound and install the packing flange nuts (Key 12), with the material guide markings facing up. Tighten the nuts to the appropriate valve size torque value as indicated in Table 3.



Lapping

If the seat ring and plug seating surface are in good condition, properly performed seat lapping can restore valve seat tightness.

- 1** Clean the seating surface of the plug and seat ring with a 400-600 grit emery cloth, or Scotch-brite™ pad.
- 2** Install the seat ring (Key 16) using the Body Reassembly instructions.
- 3** Apply 400-600 grit lapping compound to the seating area of the plug (Key 17).
- 4** Insert the plug and stem (Key 17) into the bonnet (Key 2), without packing.
- 5** Place bonnet (Key 2) and plug (Key 17) into the body (Key 1), and hand tighten bonnet.

Figure 3 Lapping Handle



Model
DF2000 Control Valve
 Operation, Parts and Instruction Manuals

Lapping (Cont'd)

- 6** Insert the packing box follower (Key 9) into the bonnet to help align the stem.
- 7** See Figure 3 on how to use 2 stem nuts and 2 9/16" box end wrenches as a handle to lap the seat.

! CAUTION ! _____
If you hear a squeaking noise during this operation, the seating area has become dry of lapping compound and galling of the surfaces could result.

- 8** While holding the wrenches and **applying light pressure**, make a 1/8 turn clockwise, and then a 1/8 turn counter clockwise.
- 9** After 3 cycles of turning the plug and stem, lift the stem to pull lapping compound into the seating area.

- 10** Repeat this process for 1 minute.
- 11** Remove the bonnet, plug and stem from the body.
- 12** Wipe the seating areas of the plug and seat ring.
- 13** A fine "lap line" should be visible on the seating surface of the seat ring and valve plug. This should result in sound mating surfaces.

! NOTE ! _____
If you do not see a full "lap line", evaluate if a second round of lapping can remove the deviation. Deep marks will require machining.

Seat Leakage

The DF2000 is a metal seated valve and will leak a small amount under normal conditions. The leakage rate of the DF2000 allows a Class IV leakage rating to be applied under ANSI/FCI 70-2. The standard also requires testing of the valve at the service pressure drop, or 50 psig (345 kPag), whichever is

lower. Each DF2000 is shop tested to meet the allowable leakage rate that is a percentage of the port size maximum flow rate.

! NOTE !
If you need "tight shut-off" at a high pressure drop, please consult your Dyna-Flo sales office.

Table 3

Torque Values

NOTE: Torque Packing Box in in-lb, Seat Ring and Bonnet in ft-lb.

Body Size	Packing Box Nuts (Key 5)		Seat Ring	Bonnet Hex
	Minimum in-lb (N-m)	Maximum in-lb (N-m)	(Key 16) ft-lb (N-m)	(Key 2) ft-lb (N-m)
1	40 (4.4)	50 (5.6)	300 (410)	800 (1090) (2-5/8" hex)
2	70 (7.8)	100 (11.1)	520 (710)	1500 (2030) (3-1/4" hex)

Our Commitment of Quality

Dyna-Flo is committed to continuous improvement. All efforts have been taken to maximize the accuracy of this information. Without notification, product specifications and designs may be modified at any time. The issue of this document is for information only, and does not imply suitability, a warranty, or guarantee for a specific service.



Model **DF2000** Control Valve
 Operation, Parts and Instruction Manuals

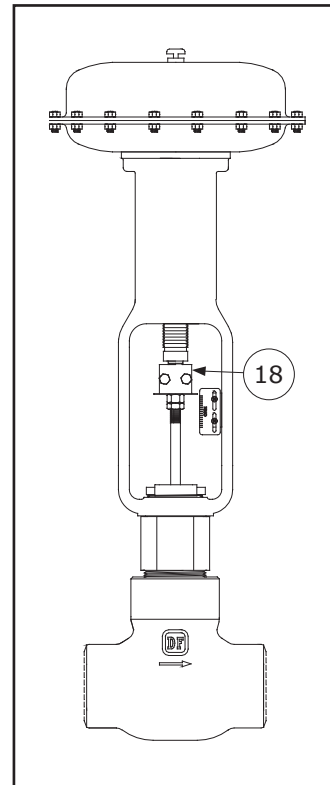
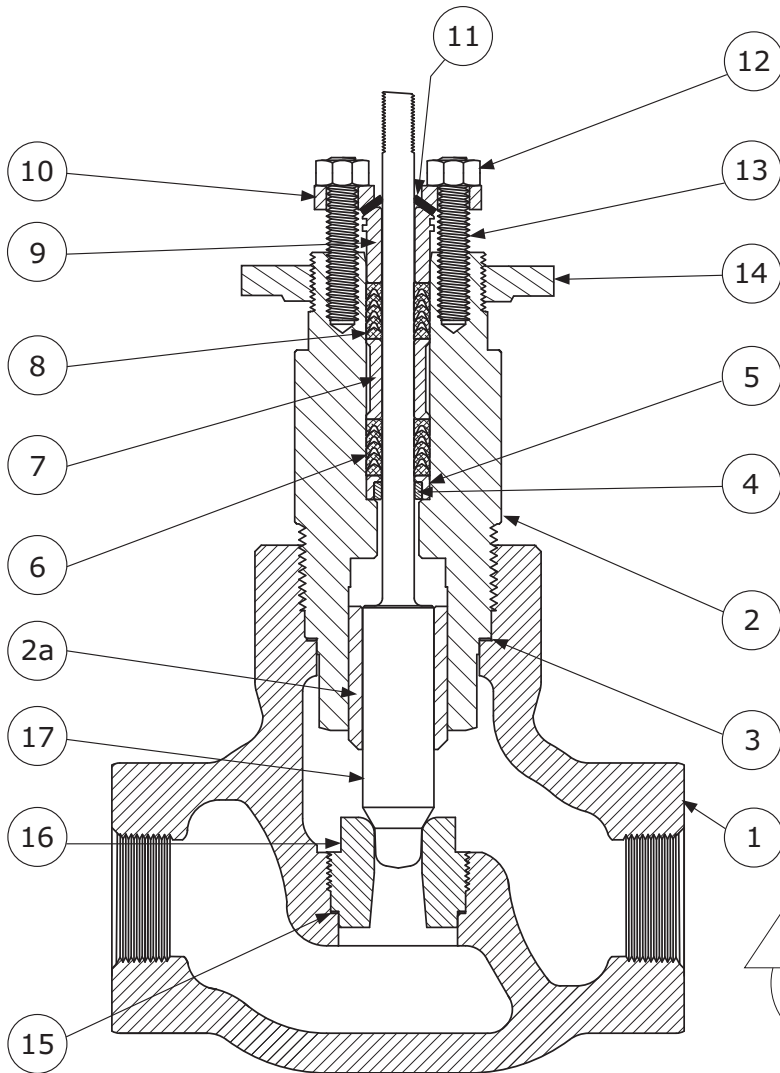

Figure 4
 Typical DF2000 Assembly
 with NPT Connections

Parts Ordering
 Whenever corresponding with Dyna-Flo about a Model DF2000 control valve, refer to the actuator nameplate or the neck of the valve body for the unit serial number. Please order by the complete part number (as given in the Parts List) of each part required.

Key	Description	Part Number	Quantity	Notes
1	Body A352LCC 1 inch 2 inch	Contact Factory Contact Factory		
2	Bonnet / Bushing Assembly A352LCC 1 inch 2 inch		2	2F1383X0M3D 2F14322409D
2a	Bushing S17400 PH DH 1150 1 inch 2 inch			included with #2 included with #2

* For Tungsten Carbide trim part numbers for non-Flute trim see parts kit in Table 4



Model
DF2000 Control Valve
 Operation, Parts and Instruction Manuals

Parts

Key	Description	Part Number
3	Bonnet Gasket S30400	
	1 inch	1B19823604D
	2 inch	1B19843604D
4	Lower Wiper PTFE	
	1 inch	1J87210699D
	2 inch	1J87220699D
5	Packing Box Ring S31600	
	1 inch	1J87313507D
	2 inch	1J87323507D
6, 8	Packing Set (2 Req'd) PTFE	
	1 inch	1R2900010DD
	2 inch	1R2902010DD
7	Packing Spacer S31600	
	1 inch	1F36413507D
	2 inch	1J96233507D
9	Packing Follower S31600	
	1 inch	1E94393507D
	2 inch	1E94433507D
10	Packing Flange Plated Steel	
	1 inch	1E94372410D
	2 inch	1E94422307D
11	Stem Wiper Felt	
	1 inch	1J87260633D
	2 inch	1J87270633D
12	Packing Nut (2 Req'd) SA-194-2H	
	1 inch	1E94402411D
	2 inch	1E94452411D
13	Packing Stud (2 Req'd) SA-193-B7	
	1 inch	1E94413103D
	2 inch	1E94443103D
14	Yoke Nute Zinch Plated Steel	
	1 inch	1E79302306D
	2 inch	1E80742306D
15	Seat Ring Gasket S30400	
	1 inch	1B19863604D
	2 inch	1B19883604D
16*	Seat Ring (Equal Percent)(See Table 4) S31600 / CoCr-A 1 inch Valve	
	1/4 inch port diameter	2B5097X001D
	3/8 inch port diameter	2B5098X001D
	1/2 inch port diameter	2B5099X001D
	3/4 inch port diameter	2B5100X001D

2 inch Valve

1/4 inch port diameter	2B5106X001D
3/8 inch port diameter	2B5107X001D
1/2 inch port diameter	2B5108X001D
3/4 inch port diameter	2B5109X001D
1 inch port diameter	2B5110X001D
1-1/4 inch port diameter	2K1801X001D

S17400 DH 1150

1 inch Valve

1/4 inch port diameter	2B5097X174D
3/8 inch port diameter	2B5098X174D
1/2 inch port diameter	2B5099X174D
3/4 inch port diameter	2B5100X174D

2 inch Valve

1/4 inch port diameter	2B5106X174D
3/8 inch port diameter	2B5107X174D
1/2 inch port diameter	2B5108X174D
3/4 inch port diameter	2B5109X174D
1 inch port diameter	2B5110X174D
1-1/4 inch port diameter	2K1801X174D

17* Plug/Stem Assembly (Equal Percent)
(See Table 4)

S31600 / CoCr-A & S20910

1 inch Valve

1/4 inch port diameter	2F1388X004D
3/8 inch port diameter	2F1389X003D
1/2 inch port diameter	2F1390X003D
3/4 inch port diameter	2F1391X003D

2 inch Valve

1/4 inch port diameter	2F1427X002D
3/8 inch port diameter	2F1428X002D
1/2 inch port diameter	2F1429X002D
3/4 inch port diameter	2F1430X002D
1 inch port diameter	2F1431X002D
1-1/4 inch port diameter	2L5331X003D

S17400 DH 1150

1 inch Valve

1/4 inch port diameter	2F1388X174D
3/8 inch port diameter	2F1389X174D
1/2 inch port diameter	2F1390X174D
3/4 inch port diameter	2F1391X174D

2 inch Valve

1/4 inch port diameter	2F1427X174D
3/8 inch port diameter	2F1428X174D
1/2 inch port diameter	SF1429X174D
3/4 inch port diameter	2F1430X174D
1 inch port diameter	2F1431X174D
1-1/4 inch port diameter	2L5331X174D

Plug/Stem Assembly (1 Flute Dyna-Flute)
S31600 / CoCr-A

1 inch Valve

1/4 inch port diameter	Contact Factory
------------------------	-----------------

2 inch Valve

1/4 inch port diameter	Contact Factory
------------------------	-----------------

S17400 DH 1150

1 inch Valve

1/4 inch port diameter	Contact Factory
------------------------	-----------------



Model
DF2000 Control Valve
 Operation, Parts and Instruction Manuals

Parts

Key	Description	Part Number
17*	Plug/Stem Assembly (1 Flute Dyna-Flute)	
	S31600 / CoCr-A	
	S17400 DH 1150	
	2 inch Valve	
	1/4 inch port diameter	Contact Factory
	Tungsten Carbide	
	1 inch Valve	
	1/4 inch port diameter	Contact Factory
	2 inch Valve	
	1/4 inch port diameter	Contact Factory
	Plug/Stem Assembly (3 Flute Dyna-Flute)	
	S31600 / CoCr-A	
	1 inch Valve	
	1/4 inch port diameter	Contact Factory
	2 inch Valve	
	1/4 inch port diameter	Contact Factory
	S17400 DH 1150	
	1 inch Valve	
	1/4 inch port diameter	Contact Factory
	2 inch Valve	
	1/4 inch Valve	
	Tungsten Carbide	
	1 inch Valve	
	1/4 inch port diameter	Contact Factory
	2 inch Valve	
	1/4 inch Valve	Contact Factory

Table 4

DF2000 Parts Kits

Description	Part Number	
	1"	2"
DF2000 S31600/CoCr-A Plug/Stem, Seat Ring, Double Packing Felt Wiper and Gaskets		
1/4 Inch Port Diameter	RDXCNTRM11D	RDXCNTRM21D
3/8 Inch Port Diameter	RDXCNTRM12D	RDXCNTRM22D
1/2 Inch Port Diameter	RDXCNTRM13D	RDXCNTRM23D
3/4 Inch Port Diameter	RDXCNTRM14D	RDXCNTRM24D
1 Inch Port Diameter	N/A	RDXCNTRM25D
1-1/4 Inch Port Diameter	N/A	RDXCNTRM26D
DF2000 S31600/Tungsten Carbide Plug/Stem and Seat Ring		
1/4 Inch Port Diameter	TDX1000007D	TDX2000007D
3/8 Inch Port Diameter	TDX1000008D	TDX2000008D
1/2 Inch Port Diameter	TDX1000009D	TDX2000009D
3/4 Inch Port Diameter	TDX1000010D	TDX2000010D
1 Inch Port Diameter	N/A	TDX2000011D
1-1/4 Inch Port Diameter	N/A	TDX2000012D
DF2000 Bonnet Gasket, Seat Ring Gasket, Packing		
Gasket Set & Packing - NACE	RDX0000CN1D	RDX0000CN2D