

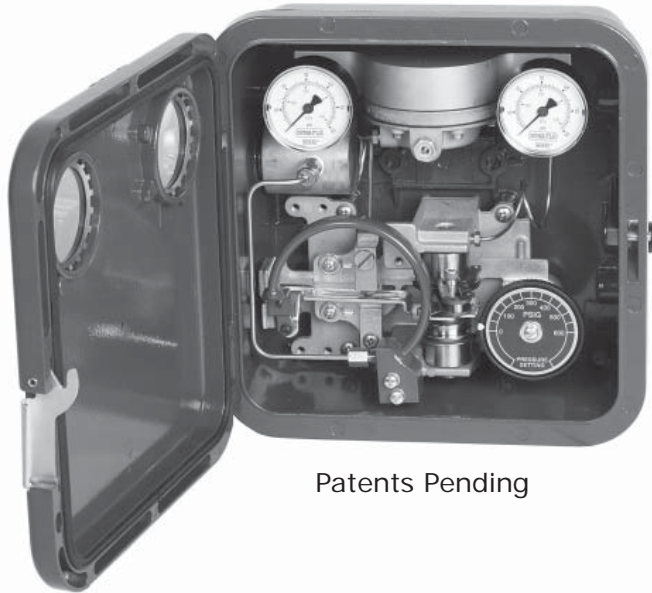

Model **4000LB** Pressure Controllers



Patents Pending

Figure 1 Model 4000LB Pressure Controller
Direct Acting Configuration

The Dyna-Flo 4000 LB controller is specially designed to reduce supply air/gas consumption. Significant reductions in the steady state bleed rates reduce emissions on fuel gas supply applications as well as instrument air consumption on plant applications. The result is a lower operating cost and less environmental impact.

Pressure controllers are the “brains” of a self contained, local pneumatic control loop. The pressure controller (Figure 1) detects the process pressure using a Bourdon tube sensing element. The process pressure is then compared to an operator-adjusted set point, which in turn modulates the controller output. The controller’s pneumatic output is connected to a final control device, typically a control valve, that changes the process pressure.

The Dyna-Flo 4000LB Series pneumatic pressure controllers are manufactured to a high level of quality specifications to ensure superior performance and customer satisfaction.

Features

Reduced Gas/Air Consumption

Steady state consumption can be reduced by 90% over standard controller designs.

Multiple Configurations

The 4000LB series pressure controller can be configured into either proportional only or proportional plus reset mode.

Rugged Design

Die cast aluminum case and cover can withstand impacts that would fracture plastic cases.

Corrosion Resistant Construction

The standard powder coated enclosure, stainless steel external fasteners, and standard stainless tubing ensure long and reliable operation.

Easily Field Reversible

Changing the action is accomplished in minutes without special tools or extensive disassembly.

Instrument Gas Tight Case

A standard feature for controlled venting when using natural gas as power gas.

Wide Range of Pressure Elements

Bourdon tube ranges from a minimum of 30 Psig (207 kPag) to a maximum 5000 Psig (34,474 kPag). Contact factory for ranges below 30 Psi.

Bourdon Tube Materials

Bourdon tube materials are S31600 for standard application and K-Monel for special applications.

Sour Instrument Gas Capability

Stainless steel gauges, relay, tubing and bellows are available for sour instrument gas supply.

Zero Bleed Relay

Soft seated relay guarantees zero leakage during steady state operation even when seats are slightly worn or dirty. Consistent low bleed rates can be assured over long term use.



Model
4000LB Pressure Controllers

Specifications

Models

- Model 4000LB - Proportional Only Controller
- Model 4010LB - Proportional-Plus-Reset Controller
- Model 4020LB - Bellows Sensing
- Model 4030LB - Differential Gap Controller

Performance

- Repeatability: 0.5% of sensing element range
- Deadband: 0.1% of output span
- Differential Gap: 15-100% of sensing element range

Reset Adjustment

For Proportional-plus-reset controller:
Adjust from 0.01 to 74 minutes per repeat
(100 to 0.01 repeats per minute).

Approximate Weight

12 pounds (5.5 kg)

Ambient Operating Temperature Limits

-40° to 160° F (-40° to 71° C)

Input Signal

Limits: See Table 1

Output Signal Range

3-15 Psig (21 to 103 kPag)
6-30 Psig (41 to 207 kPag)

Pressure Connections

All pressure connections on 4000LB Series controllers are 1/4-inch NPT female. Use 1/4-inch (6mm) or 3/8-inch (10mm) pipe or tubing for supply, and output. Vent lines should increase 1 pipe size every 10 feet, or, be kept as short as possible.

Steady-State Air Consumption

See Table 2

Supply Pressure Requirements

See Table 2

Controller Action

Control action is field reversible between direct acting (increasing sensed pressure produces increasing output signal), and reverse acting (increasing sensed pressure produces decreasing output signal) without additional parts.

Dimensions

See Figure 9

Mounting Information

Mounting Kits are available for actuator yoke, actuator casing, panel mount, wall mount and 2" pipe stand mounting. See Figure 9 and 10.

Bourdon Tube Pressure and Materials

Table 1

| Pressure Ranges | | Maximum Allowable Static Pressure Limit | | Materials |
|-----------------|------------|---|--------|-----------|
| Psig | kPag | Psig | kPag | |
| 0 - 30 | 0 - 207 | 30 | 207 | S31600 |
| 0 - 60 | 0 - 414 | 60 | 414 | S31600 |
| 0 - 100 | 0 - 689 | 100 | 689 | S31600 |
| 0 - 200 | 0 - 1379 | 200 | 1379 | S31600 |
| 0 - 300 | 0 - 2068 | 300 | 2068 | S31600 |
| 0 - 600 | 0 - 4137 | 600 | 4137 | S31600* |
| 0 - 1000 | 0 - 6895 | 1000 | 6895 | S31600* |
| 0 - 1500 | 0 - 10,342 | 1500 | 10,342 | S31600* |
| 0 - 3000 | 0 - 20,684 | 3000 | 20,684 | S31600 |
| 0 - 5000 | 0 - 34,474 | 5000 | 34,474 | S31600 |

* - Available in K-Monel (other materials and ranges special order).



Model 4000LB Pressure Controllers

Table 2

Model 4000LB Supply Pressure Requirements

| Output Signal Range Psig (kPag) | Normal Operating Supply Pressure ⁽¹⁾ Psig (kPag) | Maximum Allowable Supply Pressure (to prevent internal part damage) Psig (kPag) | Output Signal Psig (kPag) | Steady-State Air Consumption SCFH* |
|---|--|---|------------------------------|---------------------------------------|
| Throttling: 3 - 15 (21 - 103) On/Off: 0 - 20 (0 - 138) | 20 (138) | 40 (276) | 0 (0) | 1.6 |
| | | | 5 (34) | 1.5 |
| | | | 10 (69) | 1.4 |
| | | | 20 (138) | 0.3 |
| Throttling: 6 - 30 (41 - 207) On/Off: 0 - 35 (0 - 241) | 35 (241) | 40 (276) | 0 (0) | 2.6 |
| | | | 5 (34) | 2.6 |
| | | | 10 (69) | 2.6 |
| | | | 20 (138) | 2.6 |
| | | | 30 (207) | 2.5 |
| | | | 35 (241) | 0.3 |

* **SCFH:** Standard Cubic Feet per Hour (ft³/hr. 60°F and 14.7 Psig). Air flow rate indicated, for natural gas flow rate multiply by 1.29.

1. Control may be degraded if this pressure is exceeded.

Operating Principles

The Model 4000LB Series pressure controller operation is based on the pressure-balanced relay with its bridged double diaphragm assembly. In the relay, the supply pressure bleeds through the fixed orifice before passing through the nozzle, to register on the large relay diaphragm, and controller output pressure on the small relay diaphragm.

With steady state process pressure, the Bourdon tube is held steady in relation to the nozzle, allowing pressure to be released between the nozzle and beam-flapper assembly at the same rate released through the fixed orifice.

A process pressure change either expands or contracts the arc of the Bourdon tube, thereby moving the beam-flapper assembly with respect to the nozzle.

An increasing process pressure with direct action produces a nozzle to flapper restriction that increases the pressure on the large relay diaphragm, causing the relay valve to close at the exhaust end and to open at the supply end. The additional supply pressure passes through the relay housing to increase the output signal (loading pressure to the final control device).

In the opposite case of a falling process pressure with direct action creates a larger nozzle flapper gap that releases pressure from the large relay diaphragm, causing the relay valve inlet to close, thereby opening the exhaust, and reducing the output signal (loading pressure to the control device).

Proportional-Only Controllers - Model 4000LB

As the controller output changes the feed back to the proportional bellows causes the flapper position to change which counters the movement of the bourdon tube. This essentially allows the user to adjust the sensitivity of the controller by changing the resistance of the Cantilever Assembly. The resistance of the Cantilever Assembly is adjusted using the Fulcrum Set Screw. With the Fulcrum Set Screw on the lowest setting, closest to the bellows, the sensitivity of the controller is optimum. Smaller process pressure changes will create an output change at this setting. As the Fulcrum Set Screw is adjusted to a higher setting, further from the bellows, the sensitivity of the controller is decreased and larger process pressure changes will be required to create an output change. The Cantilever Assembly effectively is an adjustable proportional band of 0-100 percent.

See Figure 2 and 8 for Proportional-only controller adjustment locations.

Proportional-Plus-Reset Controllers - Model 4010LB

The 4010LB Series controllers have a two-way reset restriction valve that controls (delays) the speed of the proportional pressure flow into the reset bellows (which oppose the proportional bellows action). The reset valve can be adjusted to vary the delay (reset) time.

See Figure 3 for Proportional-plus-reset controller adjustment locations.



Model 4000LB Pressure Controllers

Operating Principles

Differential-Gap Controller - Model 4030LB

On/off action is obtained by connecting the proportional bellows so that feedback pressure forces the beam and flapper in the same direction as caused by the sensed pressure.

A decreasing process pressure with direct action (reverse action - increasing pressure) produces a nozzle to flapper restriction that reduces pressure on the large relay diaphragm. The relay valve inlet will then close and the exhaust port will open, therefore removing the output signal from the final control device.

The summing of feedback bellows movement, and the beam-flapper assembly movement, drives the relay valve either to available supply pressure or to complete exhaust, with no throttling action.

Pressure Definitions

Deadband

The amount which the measured input can change without causing a change in output signal.

Repeatability

The ability of an instrument to reproduce an output signal when a set input signal is applied repeatedly.

Differential Gap

A form of on/off control where the difference between the switch points is adjustable.

Table 3

Model 4000LB Construction Materials

| Contact | Part | Standard Material |
|---|--|--|
| With Process | Bourdon tube | Stainless steel |
| | Pressure block | Forged steel |
| | Control tubing | Stainless steel |
| With Operating Medium (at pressure) | All other interior tubing | Stainless steel |
| | Nozzle and reversing block | Stainless steel/Aluminum |
| | Relay springs and spring plate | Steel |
| | Relay diaphragms | Neoprene/Nylon |
| | Other metal relay parts | Zinc/Aluminum/Stainless steel |
| | Proportional, reset bellows | Stainless steel |
| | O-rings | Nitrile |
| | Gaskets | Neoprene |
| | Reset valve assembly | Aluminum/Stainless steel |
| With Operating Medium (at atmospheric pressure) | Case and adjustment dial | Powder Coated Aluminum |
| | Cover | Powder Coated Aluminum |
| | Flapper | Stainless steel |
| | Control link | Stainless steel |
| | Flexure and pressure setting adjustment assemblies | Aluminum/Steel/Stainless steel/Plastic |
| | O-rings | Nitrile |
| | Calibration adjuster | Aluminum |
| Proportional Band Adjustment Cantilever | S17400 PH | |



Model
4000LB Pressure Controllers

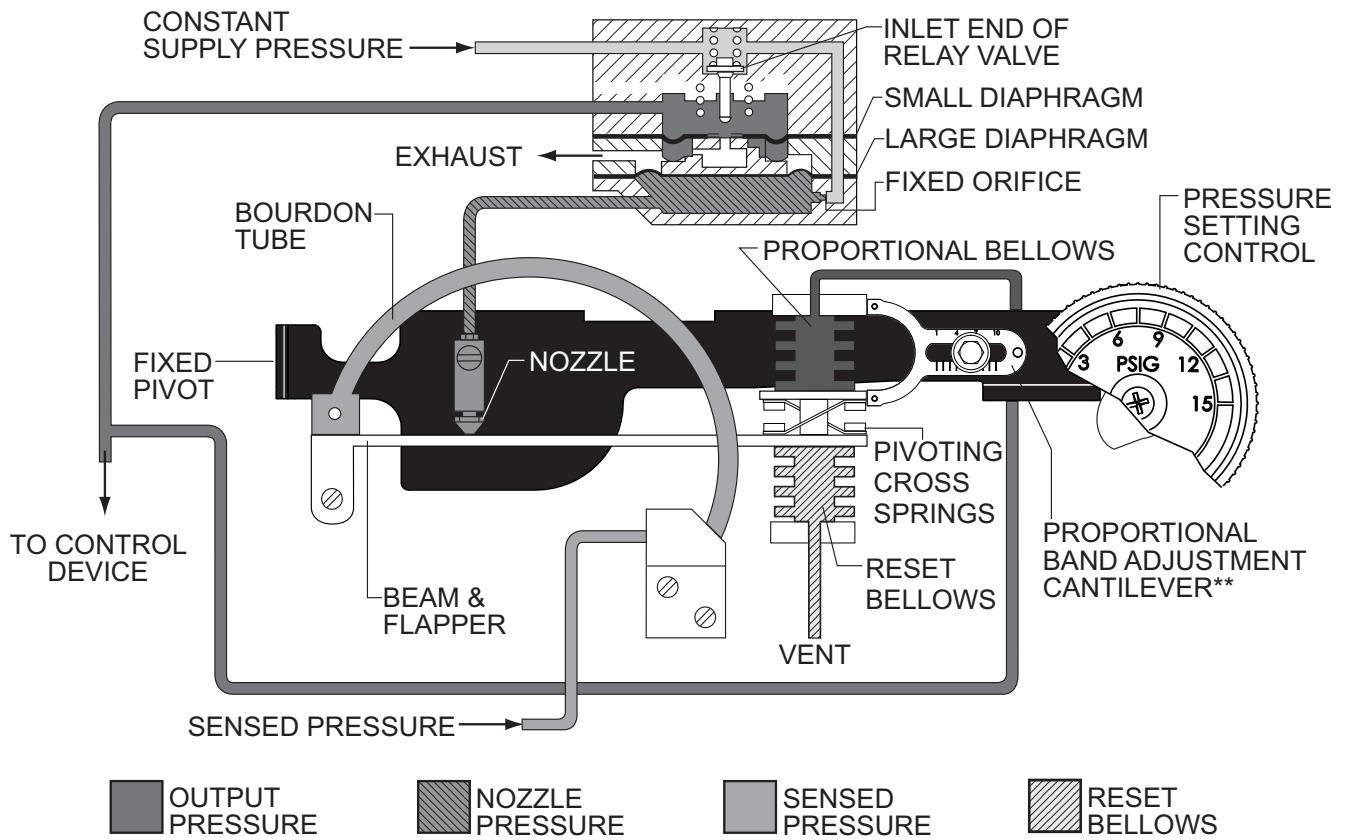

** NOTE: PROPORTIONAL BAND ADJUSTMENT CANTILEVER IS DISPLAYED FROM A TOP VIEW FOR PURPOSES OF SCHEMATIC. SEE FIGURES 4 & 6 FOR TRUE ORIENTATION.

Figure 2 Operational Schematic for Direct Acting Proportional-Only 4000LB Controller



Model
4000LB Pressure Controllers

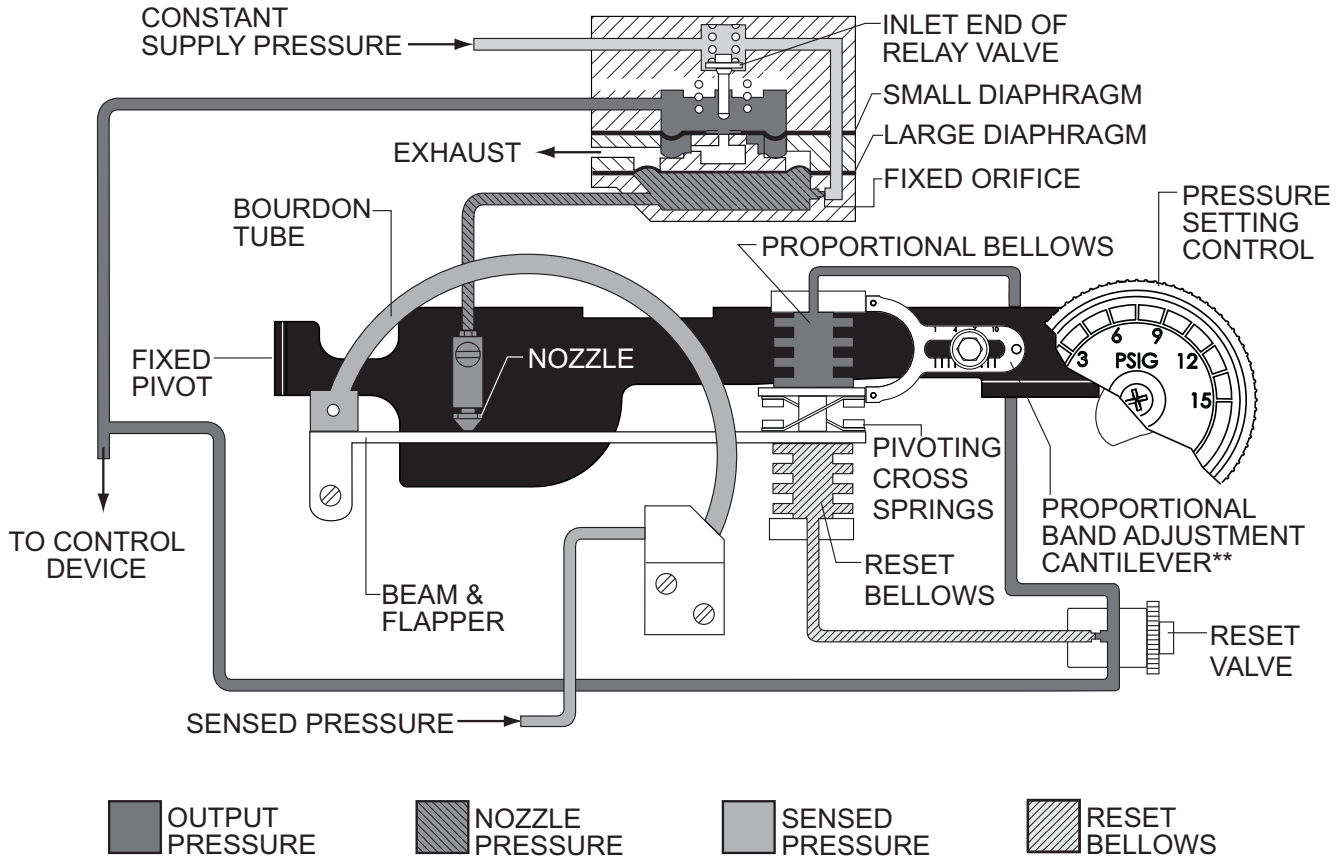

** NOTE: PROPORTIONAL BAND ADJUSTMENT CANTILEVER IS DISPLAYED FROM A TOP VIEW FOR PURPOSES OF SCHEMATIC. SEE FIGURES 5 & 7 FOR TRUE ORIENTATION.

Figure 3 Operational Schematic for Direct Acting Proportional-Plus-Reset 4000LB Controller



Model
4000LB Pressure Controllers

Figure 4
Direct Acting Proportional-
Only 4000LB Controller

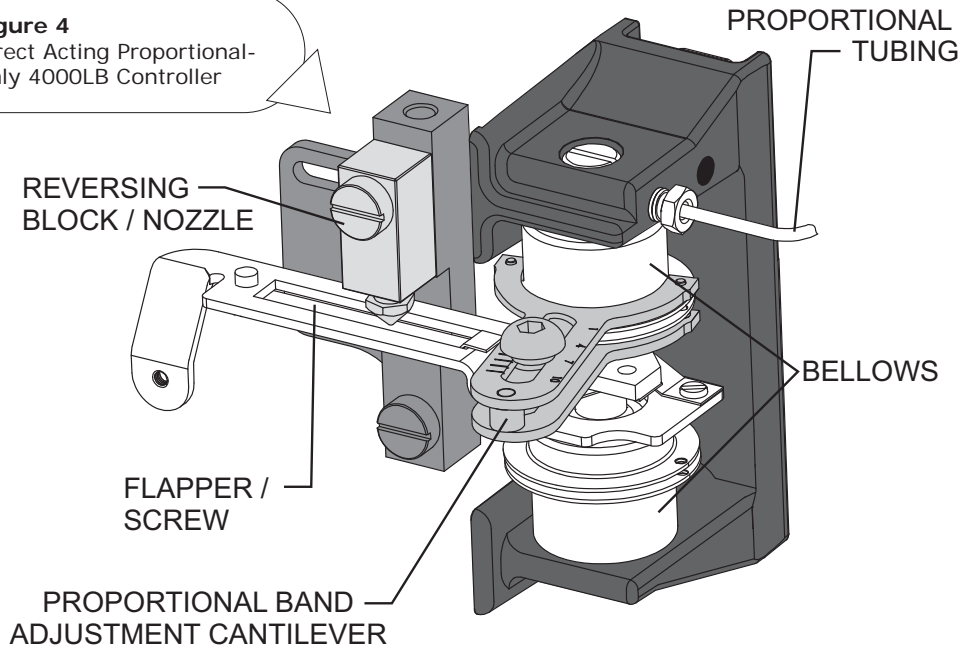

DIRECT ACTING

Figure 5
Reverse Acting Proportional-
Only 4000LB Controller

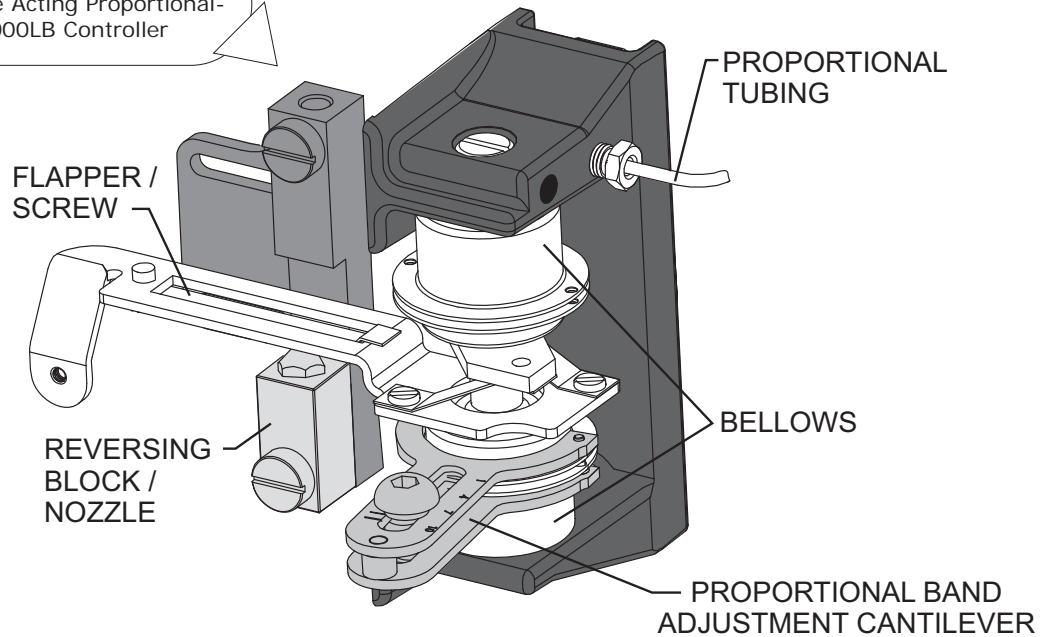

REVERSE ACTING



Model
4000LB Pressure Controllers

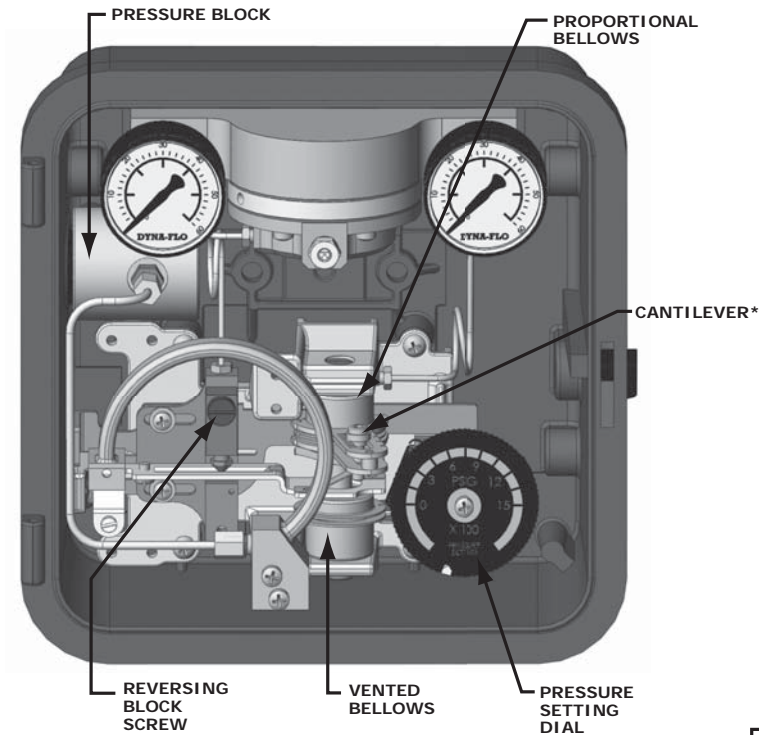
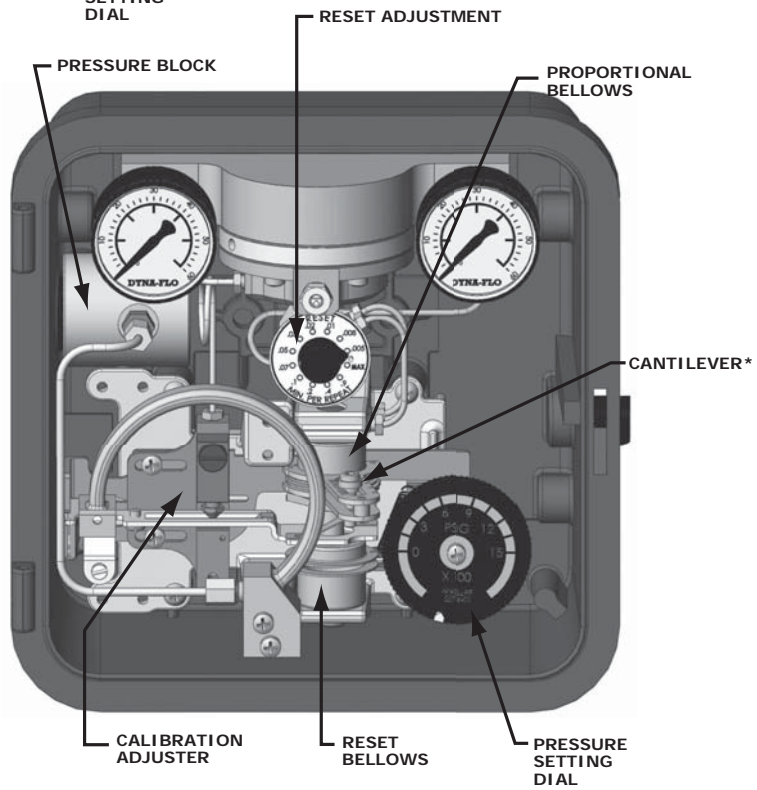

Figure 6
Direct Acting Proportional-Only 4000LB Controller

Figure 7 Direct Acting Proportional-Plus-Reset 4000LB Controller



*PROPORTIONAL BAND ADJUSTMENT CANTILEVER



Model
4000LB Pressure Controllers

Figure 8 Proportional Band Design Setting Comparison

Model 4000 Proportional Band
Adjustment Knob Set at 1.5



Model 4000LB Proportional Band
Adjustment Cantilever Set Screw
Set at 1.5

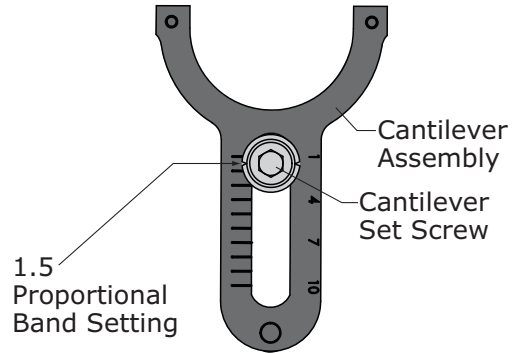

Model 4000 Proportional Band
Adjustment Knob Set at 5



Model 4000LB Proportional Band
Adjustment Cantilever Set Screw
Set at 5

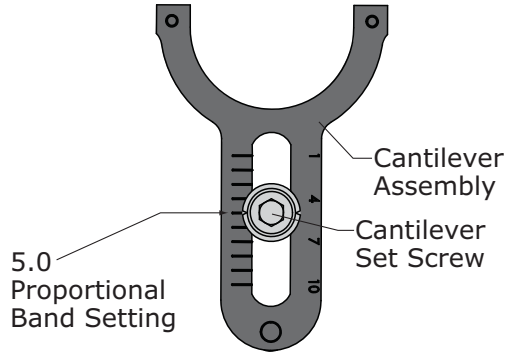

Model 4000 Proportional Band
Adjustment Knob Set at 9



Model 4000LB Proportional Band
Adjustment Cantilever Set Screw
Set at 9

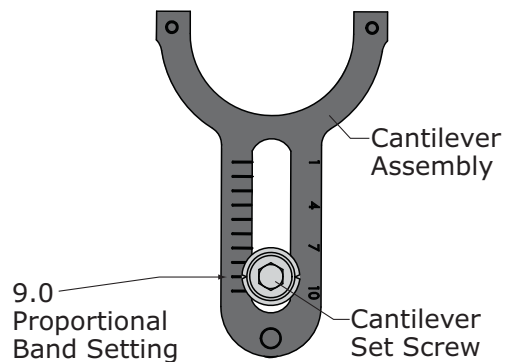



Model
4000LB Pressure Controllers

Figure 9 Dimensions, and Panel, Wall, and Pipestand Mounting

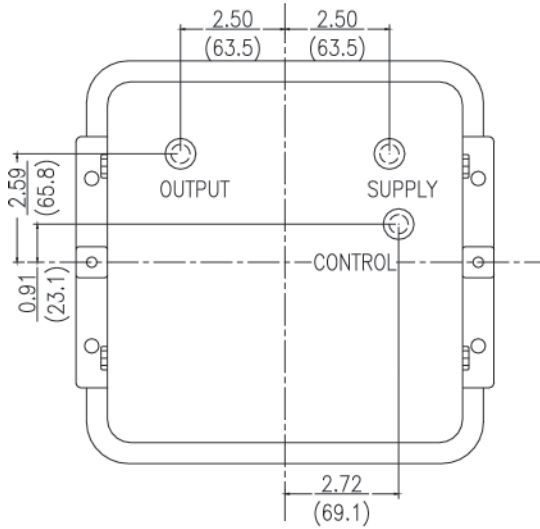

Pipestand Mounting

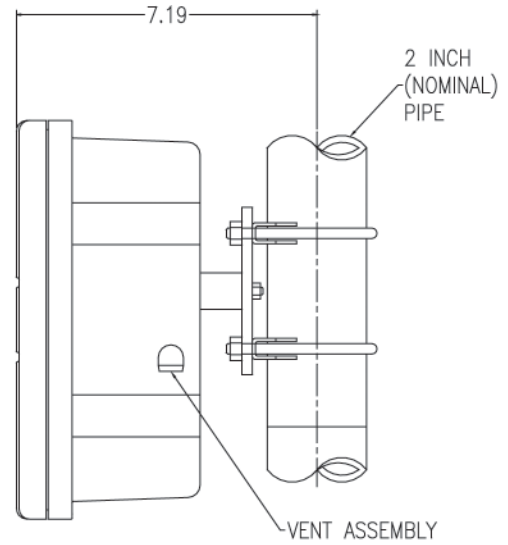

Back View

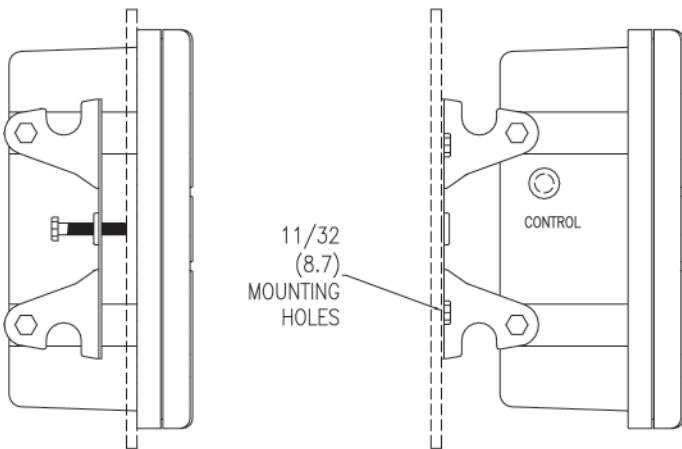

Panel Mounting

Wall Mounting

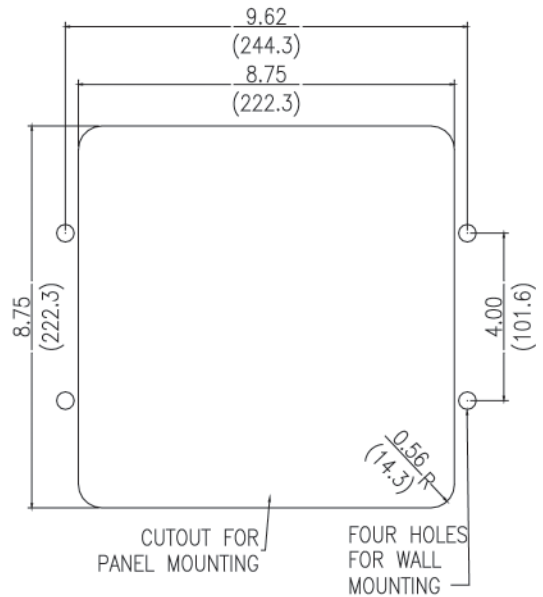

CUTOUT FOR PANEL MOUNTING

FOUR HOLES FOR WALL MOUNTING

INCH
(mm)



Model
4000LB Pressure Controllers

Figure 10
Actuator Mounting

NOTE
When using yoke style or
pipestand mounting,
DON'T PUNCH HOLES
in back of case.
Use drill (5/16 bit).

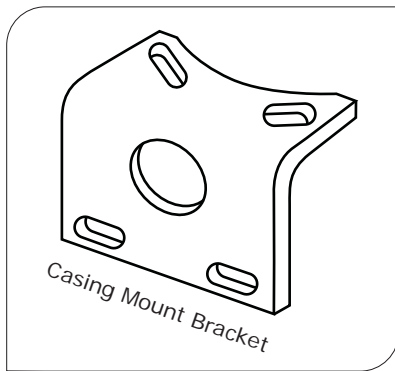
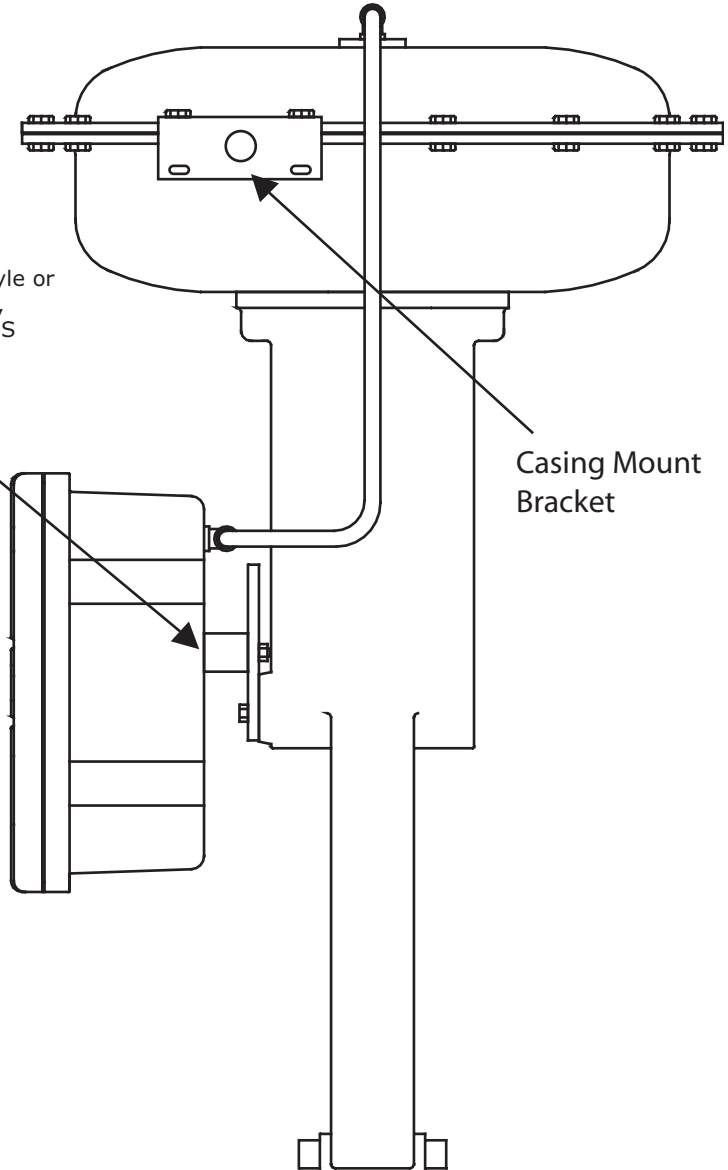

Casing Mount Bracket

Our Commitment of Quality

Dyna-Flo is committed to continuous improvement. All efforts have been taken to maximize the accuracy of this information. Without notification, product specifications and designs may be modified at any time. The issue of this document is for information only, and does not imply suitability, a warranty, or guarantee for a specific service.



Model **4000LB** Pressure Controllers

Dyna-Flo 4000LB Pressure Controller | Model Numbering System

Ordering Guide

Sample Part Number

4000LB-010-D-10

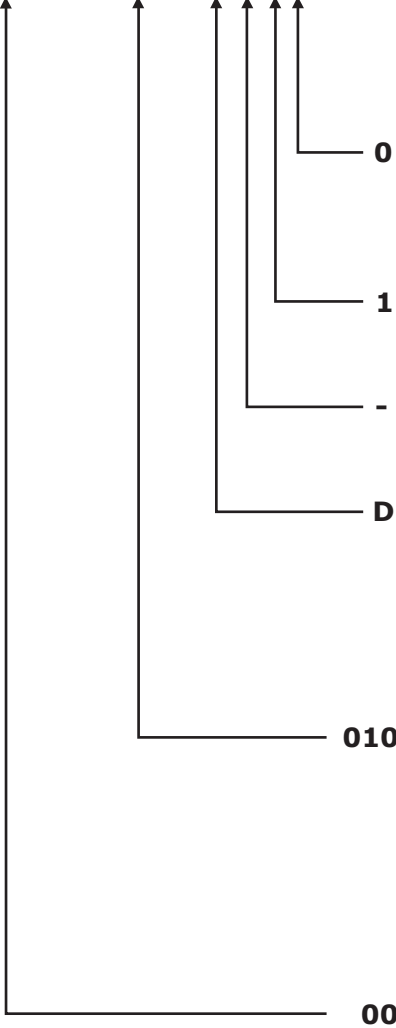

| Code | Description |
|--|--|
| Options | |
| 0 | None |
| 1 | NACE Process Only |
| 2 | Sour Instrument Only |
| 3 | NACE Process and Sour Instrument |
| X | Special |
| Controller Output | |
| 1 | 3 to 15 psig (21 to 103 kPag) / 0 to 20 psig (0 to 138 kPag) |
| 2 | 6 to 30 psig (41 to 207 kPag) / 0 to 30 psig (0 to 207 kPag) |
| Options | |
| - | None (standard) |
| S | Bourdon Tube Stop |
| Controller Action | |
| D | Direct |
| R | Reverse |
| Input Signal Range | |
| 003 | 0 to 30 Psig (207 kPag) |
| 006 | 0 to 60 Psig (414 kPag) |
| 010 | 0 to 100 Psig (689 kPag) |
| 020 | 0 to 200 Psig (1379 kPag) |
| 030 | 0 to 300 Psig (2068 kPag) |
| 060 | 0 to 600 Psig (4137 kPag) |
| 100 | 0 to 1000 Psig (6895 kPag) |
| 150 | 0 to 1500 Psig (10342 kPag) |
| 300 | 0 to 3000 Psig (20684 kPag) |
| 500 | 0 to 5000 Psig (34474 kPag) |
| Note: consult factory for higher input signal ranges | |
| Controller Mode | |
| 00 | Proportional |
| 10 | Proportional + Reset |
| 20 | Bellows Sensing |
| 30 | Differential Gap |

NOTE: order mounting kits separately