

# Model DFRP Rotary Actuator

## Operation, Parts, and Instruction Manual

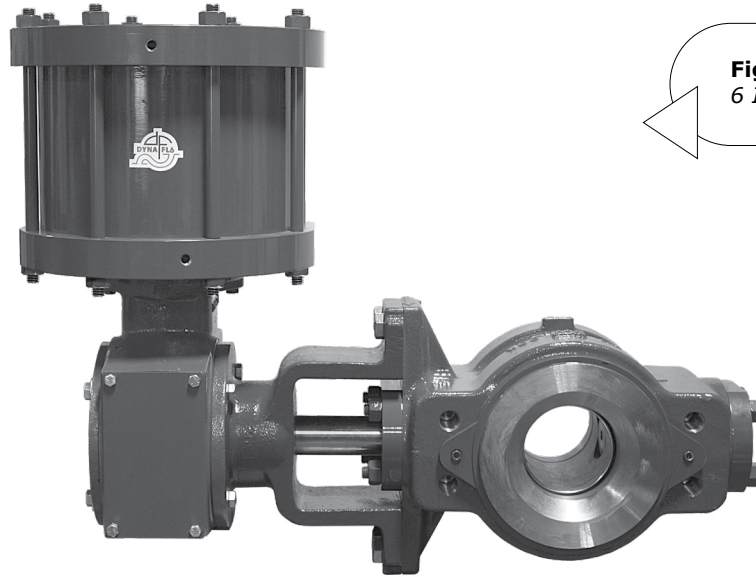

**Figure 1**  
6 Inch 590 with DFRP-112

### TABLE OF CONTENTS

<b>General</b>	<b>2</b>	<b>Actuator Assembly</b>	<b>17</b>
<b>Scope</b>	<b>2</b>	Bushing / Yoke Assembly	17
<b>Principles of Operation</b>	<b>2</b>	Cylinder Assembly	18
<b>Safety Caution</b>	<b>2</b>	Piston Assembly	19
<b>Specifications</b>	<b>3</b>	Lever Installation	21
<b>Unpacking</b>	<b>4</b>	Cover Plate Assembly	22
<b>Installation</b>	<b>4</b>	Cover Plate Installation	22
Air Piping	4	Plate & Vent Installation	23
<b>Actuator Mounting</b>	<b>4</b>	<b>DFRP Actuator Cross Section - Figure 29</b>	<b>24</b>
<b>Actuator Adjustment</b>	<b>8</b>	<b>Mounting Bolt Torque Specifications - Table 2</b>	<b>25</b>
<b>Changing Actuator Style</b>	<b>11</b>	<b>DFRP Torque Specifications - Table 3</b>	<b>25</b>
<b>DFRP Mounting Positions - Figure 13</b>	<b>12</b>	<b>Open-End Wrench Sizes - Table 4</b>	<b>25</b>
<b>DFRP Operating Positions - Figure 14</b>	<b>12</b>	<b>Parts</b>	<b>26</b>
<b>DFRP Mounting Styles &amp; Positions - Table 1</b>	<b>13</b>	<b>Model Builder</b>	<b>32</b>
<b>Actuator Disassembly</b>	<b>13</b>		
Cover Plate Disassembly	13		
Cylinder Disassembly	14		
Yoke Removal / Disassembly	15		



# Model DFRP Rotary Actuator Operation, Parts, and Instruction Manual

## NOTICE

These instructions are meant to be used with the Dyna-Flo DFRP Technical Sales Bulletin as they refer to Figures and Tables therein. If you do not have the Technical Sales Bulletin, contact Dyna-Flo immediately, or visit [www.dynaflo.com](http://www.dynaflo.com)

Each actuator is factory checked. Check the calibration for the specific application, before a valve or actuator is put into service.

It is the intention of this document to provide users with an accurate guide for safe installation and maintenance of the DFRP Actuator. Revisions and updates are available at above mentioned website.

## GENERAL

**The following instructions are to be thoroughly reviewed and understood prior to installing, operating or performing maintenance on this equipment. Work on this equipment should be performed by experienced personnel. Throughout the manual, safety and caution notes appear and must be strictly followed to prevent serious injury or equipment malfunction.**

## SCOPE

The actuator configuration and construction materials were selected to meet particular pressure, temperature, operating medium, and process fluid conditions. Some material combinations are limited in their pressure and temperature ranges. Do not apply any other conditions to the actuator without first contacting your Dyna-Flo sales office.

This manual is written to be a practical and useful guide for maintaining the Dyna-Flo DFRP Actuator.

## PRINCIPLES OF OPERATION

The DFRP actuator works by loading air pressure on one side of the piston (Key 20), and unloading air pressure from the other side of the piston to achieve piston movement. If there is no positioner being used with the control valve, a loading device (such as a 4-way switching valve) must be used. Loading devices do not come equipped standard with the actuator. Refer to appropriate positioner instruction manual as required.

### SAFETY CAUTION

**Only well trained experienced technicians should perform these procedures. Use safe work practices and lock out procedures when isolating valves and actuators. It is also important to wear the proper protective equipment when performing any installation or maintenance activity. Use only parts and materials rated for the process being used, operating conditions, and environmental conditions products will be used in.**

**To avoid personal injury or installation damage as a result of the sudden release of process pressure or damage to equipment, do not install the actuator assembly where service conditions could exceed the limits stated in this manual, sales bulletin or on the equipment nameplates. Use government codes, accepted industry standards and good piping practices, and select proper pressure-relieving equipment for protection of your installation. Always be aware of flammable process and instrument gas.**

**Always be aware of the hazards of actuators, especially spring-loaded actuators. Be sure that the actuator is de-energized or in the failed position before performing any maintenance procedure.**

**These actuators have dangerous pinch points. Never put your hands inside the valve or actuator unless you are certain that the valve or actuator will not suddenly move.**

# Model DFRP Rotary Actuator

## Operation, Parts, and Instruction Manual



### SPECIFICATIONS

#### Available Actuator Sizes

028, 079, 112, 113, and 154

#### Available Actuator Configurations

- Double-Acting
- Throttling (with Positioner)
- On-Off (with Switching Device)

#### Cylinder Operating Pressure

*Minimum Recommended:*

- 20 Psig (138 kPag)
- When used with a positioner, always set supply pressure 5 psi (35 kPa) above actuator requirement but do not exceed maximum values below

*Maximum Allowable Operating Pressure:*

- Size 028:** 150 Psig (1,034 kPag)
- Size 079:** 100 Psig (689 kPag)
- Size 112:** 85 Psig (586 kPag)
- Size 113:** 150 Psig (1,034 kPag)
- Size 154:** 150 Psig (1,034 kPag)

#### Maximum Valve Shaft Rotation

90 degrees.

#### Stroking Time

Stroking Time is dependent on actuator size, rotation, and Positioner (if used). For more information consult the Dyna-Flo Sales Office.

#### Material Temperature Limitations

-40°F to 180°F (-40°C to 82°C) with standard Elastomers.

#### Pressure Connections

1/4 inch FNPT.

#### Travel Indication

Graduated scale and pointer located on the actuator end of the valve shaft.

#### Cylinder Displacement

See Table 5 of Sales Bulletin.

#### Actuator Mounting

Right-hand, or Left-hand (as viewed from seal end of valve). In one of 4 positions (12 (Std.), 3, 6, and 9 o'clock) with respect to the valve body in a horizontal pipe.

#### Construction Materials

See Table 1 for construction materials. Contact your Dyna-Flo sales office for more information and other options.

#### Valve Dimensions

See Figure 5 of Sales Bulletin for actuator diagram. See Tables 3 & 4 of Sales Bulletin for actuator dimensions.

#### Maximum Torque (at Max. Operating Pressure)

- Size 028:** 7,104 lbf-in (803 N•m)
- Size 079:** 13,800 lbf-in (1,559 N•m)
- Size 112:** 16,896 lbf-in (1,909 N•m)
- Size 113:** 56,004 lbf-in (6,328 N•m)
- Size 154:** 65,004 lbf-in (7,345 N•m) (with 2-1/2" spline shaft diameter)

See Figures 6 & 7 of Sales Bulletin for Actuator Torque Charts and Table 7 of Sales Bulletin for Breakout Torques.

#### Approximate Actuator Weights

- Size 028:** 62 lb (28 Kg)
- Size 079:** 85 lb (39 Kg)
- Size 112:** 120 lb (54 Kg)
- Size 113:** 245 lb (111 Kg)
- Size 154:** 295 lb (134 Kg)

For more information and other options contact your Dyna-Flo sales office.



# Model DFRP Rotary Actuator

## Operation, Parts, and Instruction Manual

### UNPACKING VALVE FROM SHIPPING CONTAINER

#### Special Tools Required:

- Properly Rated Lifting Straps (2 – 4 Straps) See Table for actuator weights.
- Lifting Device (Example: Crane)

Check the packing list, verify that the list includes all the materials in the shipping container before unpacking.

Place the lifting straps around the neck of the actuator and valve body if attached (See Figure 2). Straps should be placed to avoid damage to tubing and other mounted accessories.

**Figure 2**  
*Suggested Lifting Strap Placement*

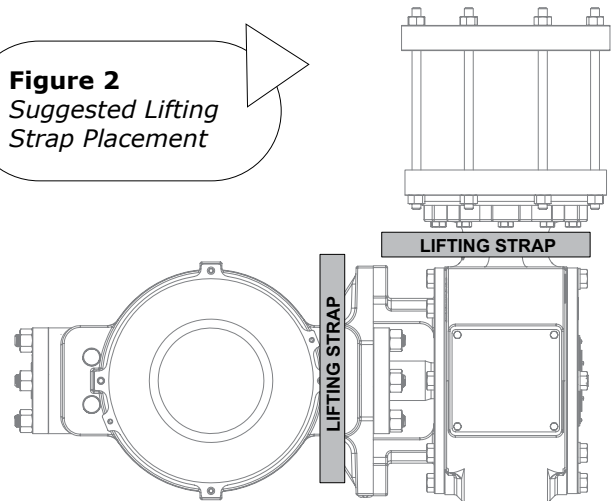

### INSTALLATION

#### Before You Begin:

- Read the General and Scope section of this manual (Page 2).
- Read Safety Caution (Page 2).
- Sudden movement of actuator can cause damage or injury. It helps to have the actuator de-energized as long as the valve installation will permit.
- Use safe work practices and lock out procedures before placing valve in-line.

Actuators are typically shipped from factory as an assembly already mounted to the valve. Follow the appropriate valve installation instructions to install the actuator / valve assembly. If the actuator was shipped separately, it will be necessary to mount the actuator on the valve prior to installation, refer to the Actuator Mounting section.

Operating medium must be controlled and directed, if a positioner was not ordered or unavailable, use a loading device such as a 4-way switching valve (not provided with the actuator). For more information on positioner installation and operation, refer to the appropriate positioner instruction manual for your positioner type.

### AIR PIPING

#### WARNING:

Property damage, environmental harm, and personal injury can result from the use of supply gas other than clean, non-corrosive, oil and moisture free air. Do not exceed the supply pressure indicated on the serial plate located on the actuator.

#### Before You Begin:

- Note:** Standard actuators accept 1/4" (6 mm) NPT connections.
- Refer to the appropriate actuator instruction manual when necessary.

#### Piping Installation Steps:

- 1 Use 3/8" (10 mm) outside diameter tubing (or equivalent) for air lines. Keep length of tubing as short as possible to prevent transmission lag in the control signal.
- 2 Install the required line vents, valves, drains, seals, and filters to the actuator.

### ACTUATOR MOUNTING

#### Before You Begin:

- Read the General and Scope section of this manual (Page 2).
- Read Safety Caution (Page 2).
- Use safe work practices and lock out procedures.
- Disconnect supply lines (air or gas), electric power, or control signal to the actuator. Sudden movement of actuator can cause damage or injury, make sure actuator will not operate.
- Vent any pneumatic actuator loading pressure.
- Relieve process pressure and drain the process fluid from up and down stream of valve.
- Be aware of potentially hazardous process material that may be present in-line and in-valve. Isolate the valve from process pressure. Use a bypass or block valve if necessary, or completely shut off the process. Relieve internal valve pressure (refer to the appropriate valve instruction manual).

# Model DFRP Rotary Actuator

## Operation, Parts, and Instruction Manual



### ACTUATOR MOUNTING (Continued)

#### Special Tools Required:

- 6" metal rod (between 1/4" and 3/8" diameter). See note.

#### Lubricants Required:

- Anti-Seize Compound (Key A)
- Silicone-based O-Ring Compound (Key B)
- White Petroleum Grease (Key C)
- Refined Petroleum Oil (Key E)

- 1 Secure the valve assembly in place on a flat work surface that will support the weight of the combined valve and actuator assembly.
- 2 Remove any positioners and/or instrumentation installed on the actuator.
- 3 Remove the cover plate cap screws (Key 47) and washers (Key 46).
- 4 Remove the cover plate/bushing assembly (Keys 38, 39, 40, 41, 42, 43, 44, and 45).

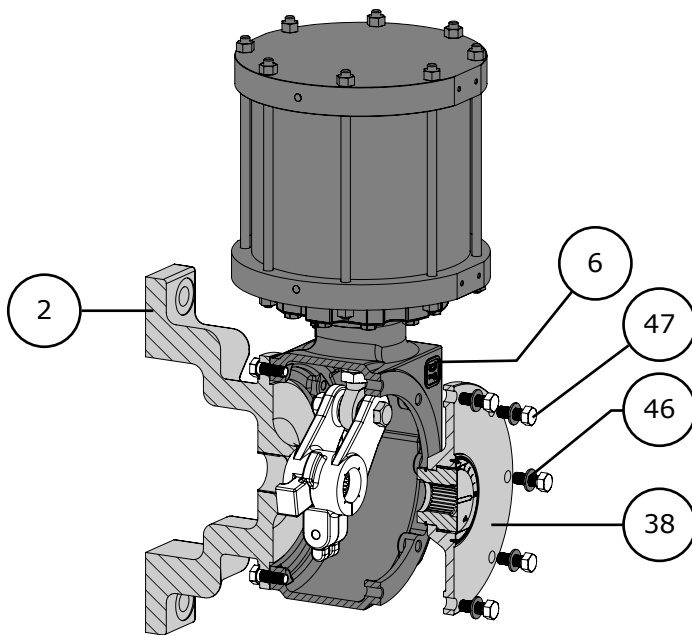

**Figure 3** Cover Plate Assembly Removal

- 5 If the lever (Key 32) is attached to the rod end bearing (Key 31), disconnect the lever from the rod end bearing and remove the lever:

#### For actuator sizes 028, 079, and 112:

Remove the cap screw (Key 35) and hex nut (Key 37).

#### For actuator sizes 113 and 154:

Remove the cap screw (Key 35), hex nut (Key 37), and washer (Key 36).

- 6 Slide the actuator onto the valve shaft as shown in Figure 20. Refer to Figures 8, 13, and 14 for actuator mounting positions and orientation. Once the actuator is installed on the valve shaft in the proper orientation, secure the actuator in place using the mounting bolts (Key 3) and lockwashers (Key 4) for Model 590 valves (refer to Figure 20. Mounting to Model 570 valves will require a hex nut (Key 5).

**Note:** See Table 4 for required wrench sizes for turnbuckle assembly adjustment for Steps 7 – 9. For size 112 actuators, turnbuckle (Key 29) and hex nut (Key 28) adjustment will require a 6" (152 mm) long rod that is between 0.25" (6.4 mm) and 0.375" (9.5 mm) in diameter.

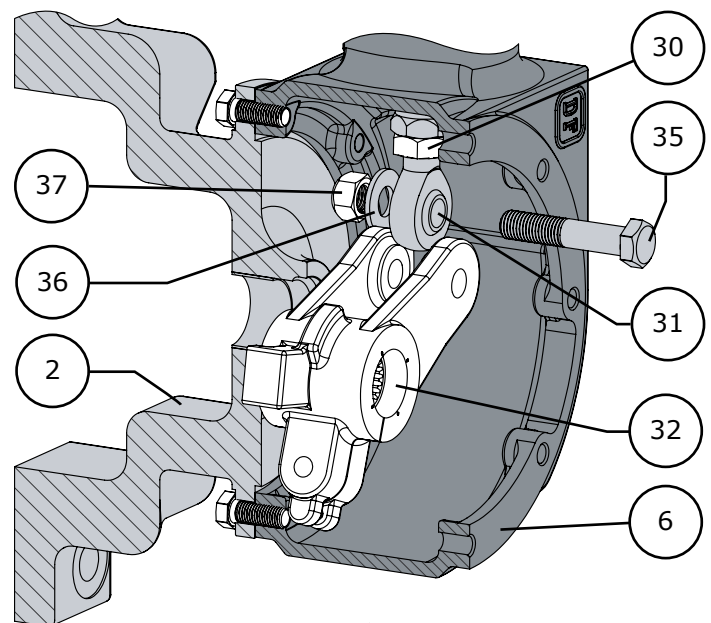

**Figure 4** Lever Removal



# Model DFRP Rotary Actuator

## Operation, Parts, and Instruction Manual

### ACTUATOR MOUNTING (Continued)

- 7 Turn the hex nut (Key 28) until it reaches the top of the threaded portion of the piston rod (Key 19). Leave the hex nut finger tight, it will be re-adjusted later.
- 8 Turn the turnbuckle (Key 29) until it makes contact with the hex nut (Key 28) at the top of the piston rod (Key 19). Leave the turnbuckle finger tight, it will be re-adjusted later.
- 9 Turn the lower hex nut (Key 30) down onto the rod end bearing (Key 31) as far as it will go. Leave the hex nut finger tight, it will be re-adjusted later.
- 10 Thread the rod end bearing (Key 31) into the turnbuckle (Key 29) as far as it will go. Leave the rod end bearing finger tight, it will be adjusted later.
- 11 Lubricate the teeth of the valve shaft spline with refined petroleum oil (Key E).
- 12 Loosen the lever clamp cap screw (Key 33). It may be necessary to tighten the lever adjustment set screw (Key 34) to spread the split portion of the lever (Key 32) to allow for easier installation (set screw may not be included on all actuator sizes).
- 13 Install the lever onto the valve shaft (Key V). Refer to Figures 7, 8, and 14 and appropriate valve instruction manual for proper lever orientation.
- 14 Adjust the position of the lever (Key 32) so that the rod end bearing (Key 31) will be in alignment between the cap screw holes of the lever. Loosen the set screw (Key 34). **Note:** Refer to Figure 9 for lever operating clearance. It may be necessary to remove the positioner plate (Key 48) or the access plate (Key 50) in order to verify the lever operating clearance.
- 15 Connect the lever (Key 32) to the rod end bearing (Key 31). Refer to Figure 25 & 26:
  - For actuator sizes 028, 079, and 112:**
    - A Install the cap screw (Key 35) through the lever (Key 32) and rod end bearing (Key 31). **Note:** It may be necessary to adjust the turnbuckle (Key 29) in order to meet alignment.
    - B Thread the hex nut (Key 37) onto the cap screw (Key 35) and tighten to the torque value specified in Table 3.

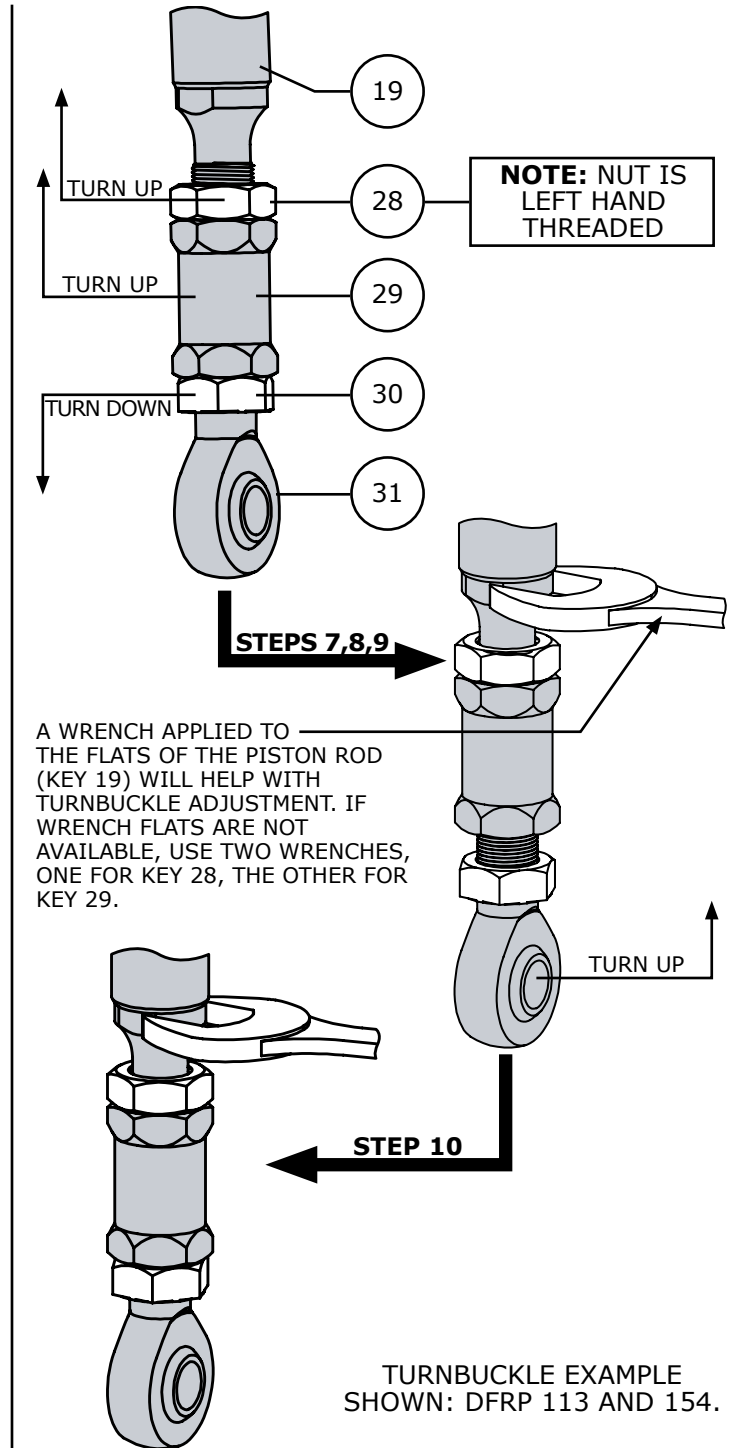

Figure 5 Turnbuckle Assembly Adjustment



# Model DFRP Rotary Actuator

## Operation, Parts, and Instruction Manual

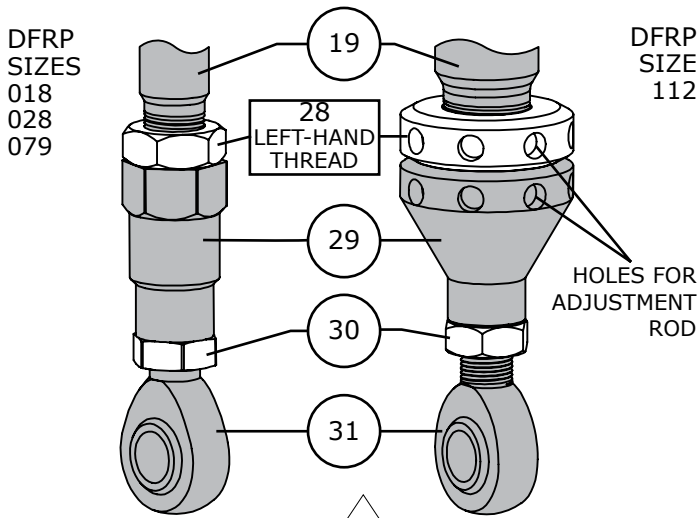

Figure 6 Turnbuckle Examples

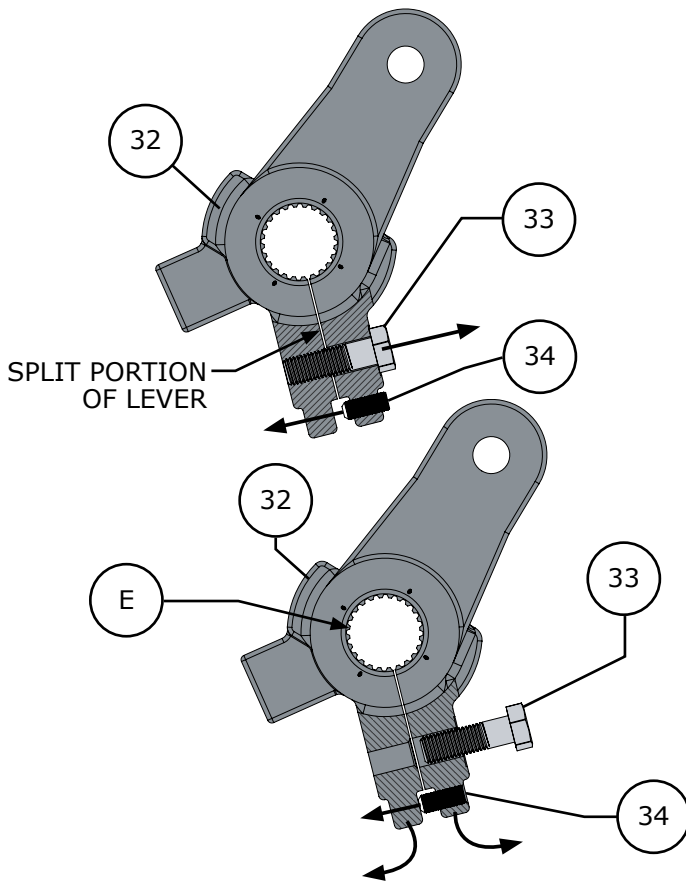

Figure 7 Step 12 Lever Clamp Loosening

### ACTUATOR MOUNTING (Continued)

15 Connect the lever (Key 32) to the rod end bearing (Key 31) (Continued):

#### For actuator sizes 113 and 154:

- A Install the cap screw (Key 35) through the lever (Key 32) and rod end bearing (Key 31). **Note:** It may be necessary to adjust the turnbuckle (Key 29) in order to meet alignment.
- B Install the washer (Key 36) onto the cap screw (Key 35).
- C Thread the hex nut (Key 37) onto the cap screw (Key 35) and tighten to the torque value specified in Table 3.

16 Check the position of the valve ball or disk and note the direction of rotation for valve operation.

#### For actuators without a handwheel:

- A Re-install the cover plate assembly (Keys 38, 39, 40, 41, 42, 43, 44, and 45). Position the cover plate assembly so that the travel indicator (Key 44) will rotate according to the position of the valve ball/disk and direction of valve operation as determined above.
- B Secure the cover plate (Key 38) in place using the washers (Key 46) and cap screws (Key 47). Torque the cap screws to the recommend torque value listed in Table 3.

**Note:** If the holes of the actuator housing (Key 6) and the cover plate (Key 38) are out of alignment, it may be necessary to loosen the mounting yoke cap screws (Key 7) and reposition the actuator housing. DO NOT stroke the actuator while the cover plate is removed.

#### For actuators with a manual handwheel:

- A Contact Dyna-Flo Control Valve Services for instructions on handwheel installation for the DFRP actuator.

17 Refer to the Actuator Adjustment section (Page 8) for instructions on re-adjusting the turnbuckle assembly.



# Model DFRP Rotary Actuator

## Operation, Parts, and Instruction Manual

**Figure 8** *Lever Orientation Options*

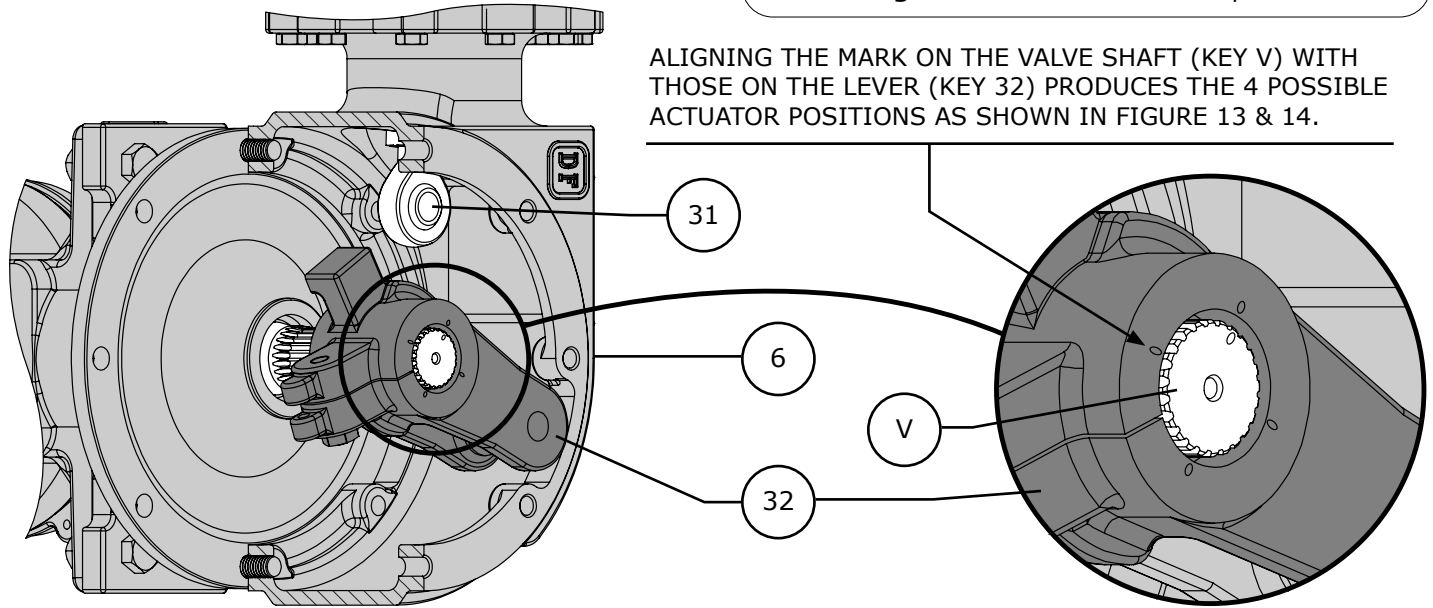

ALIGNING THE MARK ON THE VALVE SHAFT (KEY V) WITH THOSE ON THE LEVER (KEY 32) PRODUCES THE 4 POSSIBLE ACTUATOR POSITIONS AS SHOWN IN FIGURE 13 & 14.

**Figure 9** *Lever Operating Clearance*

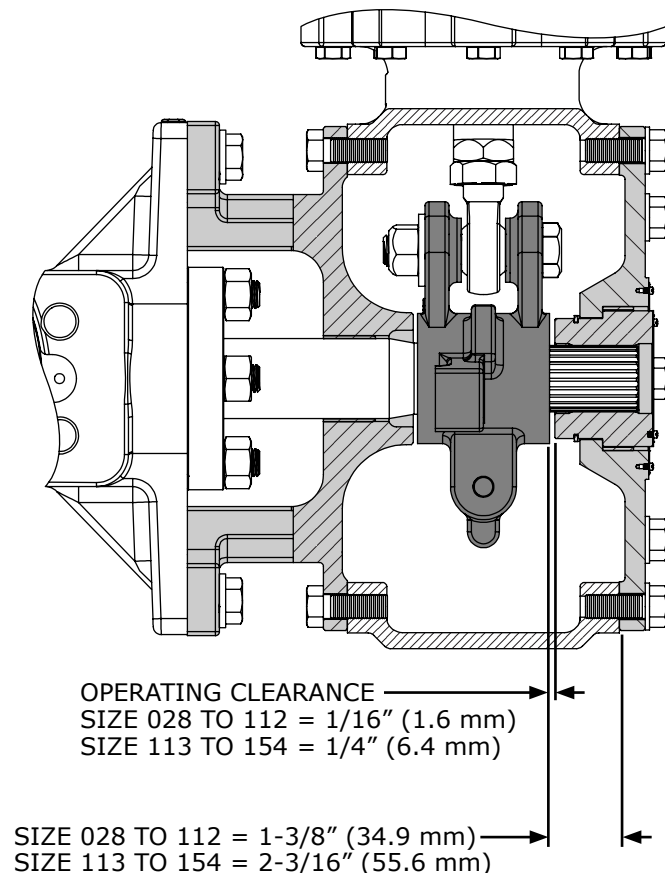

### ACTUATOR ADJUSTMENT

#### Before You Begin:

- Read the General and Scope section of this manual (Page 2).
- Read Safety Caution (Page 2).
- Use safe work practices and lock out procedures.
- Disconnect supply lines (air or gas), electric power, or control signal to the actuator. Sudden movement of actuator can cause damage or injury, make sure actuator will not operate.
- Vent any pneumatic actuator loading pressure.
- Relieve process pressure and drain the process fluid from up and down stream of valve.
- Be aware of potentially hazardous process material that may be present in-line and in-valve. Isolate the valve from process pressure. Use a bypass or block valve if necessary, or completely shut off the process. Relieve internal valve pressure (refer to the appropriate valve instruction manual).



# Model DFRP Rotary Actuator

## Operation, Parts, and Instruction Manual



### ACTUATOR ADJUSTMENT (Continued)

#### Special Tools Required:

- Regulated air supply.
- Wrenches (See Table 4 for open-end wrenches required for turnbuckle adjustment).

**For Handwheels:** If the actuator is equipped with a handwheel, disengage the handwheel from the valve shaft (Key V) and make sure that the bypass valve is closed before performing any actuator adjustments. Instructions for actuator handwheels are a separate document, contact Dyna-Flo Control Valves for more information.

**Note:** When a DFRP actuator is properly adjusted, the valve ball or disk should be properly closed once the piston (Key 20) has made contact with either a travel stop (Keys 16), cylinder base (Key 8) if there is no travel stop, or cylinder cap (Key 25). For accurate zero-degree valve ball or disk position adjustment, the control valve must be removed from the pipeline and the actuator may also need to be removed from the valve (Refer to the appropriate valve instruction manual).

- 1 Remove the cap screws (Key 51) and access plate (Key 50). **Note:** DO NOT remove the cover plate assembly (Keys 38, 39, 40, 41, 42, 43, 44, 45, 46, & 47) during actuator adjustment. The cover plate assembly supports the valve shaft (Key V) and should never be removed when stroking the actuator.
- 2 Stroke the actuator until the lower hex nut (Key 30) can be accessed through the access plate opening (where Key 50 was removed in Step 1). Loosen the lower hex nut.
- 3 Stroke the actuator until the left-hand threaded hex nut (Key 28) can be accessed through the access plate opening. Loosen the hex nut.
- 4 **For Push-Down-to-Close Actuator/Valve Configurations:** Refer to the appropriate valve instruction manual in order to determine the closed position of the valve.
  - A Slowly stroke the actuator down until the maximum operating pressure is reached. Make note of the valve ball/disk position.
  - B Adjust the turnbuckle (Key 29) as needed until the valve reaches the closed position.
  - C Lock the turnbuckle (Key 29) in place using the left-hand threaded hex nut (Key 28).

- D Stroke the actuator until the piston reaches the cylinder cap (Key 25). Lock the turnbuckle (Key 29) in place on the bottom end by tightening the hex nut (Key 30) into the turnbuckle (Do Not overtighten).
- E Check the thread engagement of the rod end bearing (Key 31) into the turnbuckle (Key 29). Adequate thread engagement will be approximately equal to the diameter of the threads of the rod end bearing.
- F Torque the lower hex nut (Key 30) to the torque value listed in Table 3.

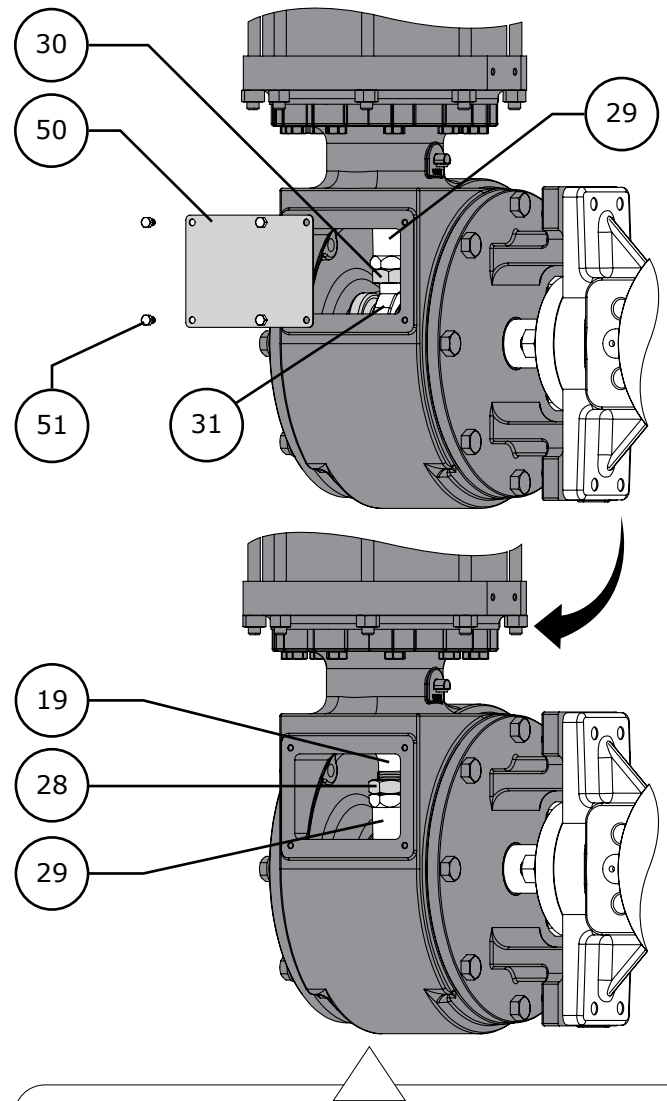

**Figure 10** Access Plate Removal



# Model DFRP Rotary Actuator

## Operation, Parts, and Instruction Manual

### PUSH-DOWN-TO-CLOSE

BALL/DISK 100% CLOSED WHEN THE PISTON (KEY 20) MAKES CONTACT WITH THE TRAVEL STOP (KEY 16)

**NOTE:** STANDARD CONSTRUCTION DOES NOT INCLUDE A TRAVEL STOP.

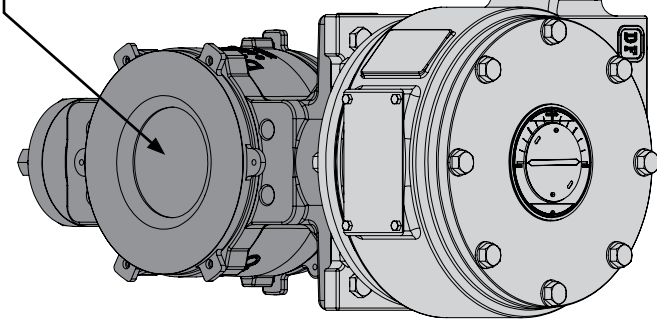
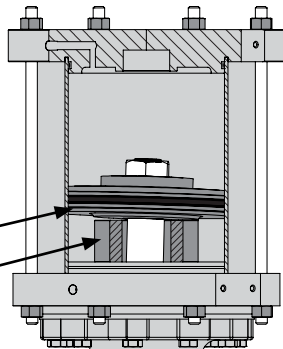

### PUSH-DOWN-TO-OPEN

BALL/DISK 100% CLOSED WHEN THE PISTON (KEY 20) MAKES CONTACT WITH THE CYLINDER CAP (KEY 25)

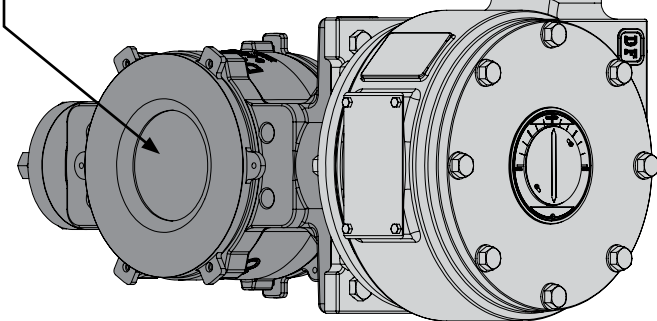
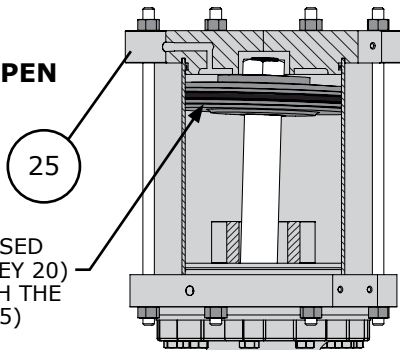

**Figure 11** Actuator Adjustment Example

### ACTUATOR ADJUSTMENT (Continued)

#### 4 For Push-Down-to-Open Actuator/Valve Configurations:

Refer to the appropriate valve instruction manual in order to determine the closed position of the valve.

- A** Slowly stroke the actuator up until the maximum operating pressure is reached. Make note of the valve ball/disk position.
  - B** Stroke the actuator until the turnbuckle (Key 29) is accessible through the access plate (Key 50) opening. Adjust the turnbuckle, valve ball/disk should visibly rotate accordingly.
  - C** Again, stroke the actuator until the hex nut (Key 23) contacts the cylinder cap to verify new ball/disk position. Continue procedure from Steps B and C until the ball/disk is fully closed when the hex nut is in contact with the cylinder cap.
  - D** Check the thread engagement of the rod end bearing (Key 31) into the turnbuckle (Key 29). Adequate thread engagement will be approximately equal to the diameter of the threads of the rod end bearing.
  - E** Stroke the actuator as necessary and lock the turnbuckle in place using the left-hand threaded hex nut (Key 28) and lower hex nut (Key 30), refer to Table 3 for torque values.
- 5** Re-install the access plate (Key 50) using the 4 cap screws (Key 51).
  - 6** If necessary, re-adjust the actuator travel scale (Key 40) appropriately by loosening the screws (Key 41) and re-tightening them once the travel scale is repositioned.

# Model DFRP Rotary Actuator

## Operation, Parts, and Instruction Manual



### CHANGING ACTUATOR STYLE

#### Mounting Styles A and D

Style A is right-hand mounted and Style D is left-hand mounted, in all other ways Styles A and D are identical. Refer to Figure 13.

#### Mounting Styles B and C

Style B is right-hand mounted and Style C is left-hand mounted, in all other ways Styles B and C are identical. Refer to Figure 13.

**Note:** To convert a Style A or D into a Style B or C actuator, the cover plate assembly (Keys 38, 39, 40, 41, 42, 43, 44, 45, 46, and 47) and the mounting yoke (Key 2) will need to be swapped. The lever (Key 32) will also need to be removed and re-installed during the conversion process. Refer to Actuator Disassembly and Assembly instructions and Figure 12 as needed.

Once an actuator has been converted to a different mounting style, the actuator must be re-adjusted.

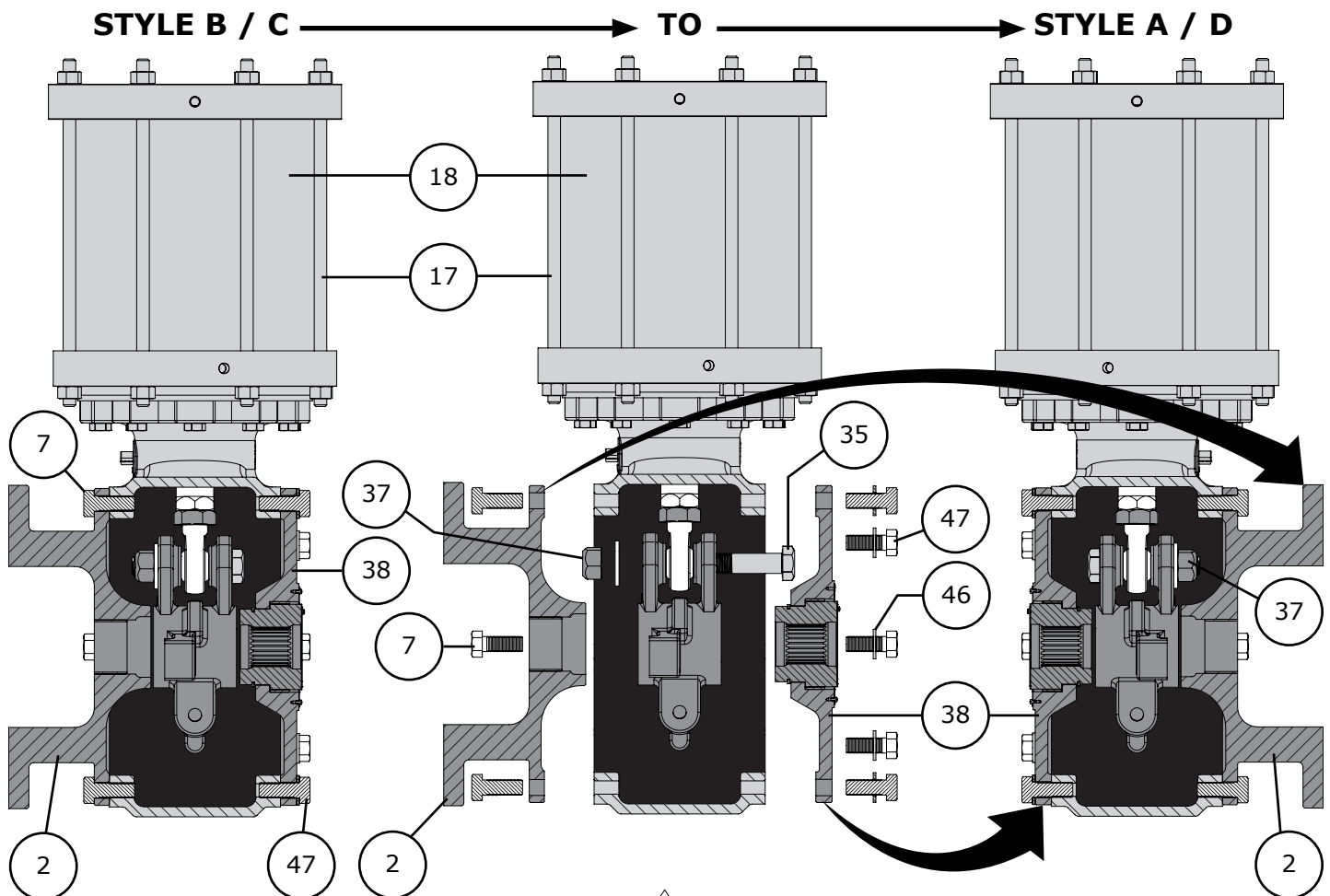
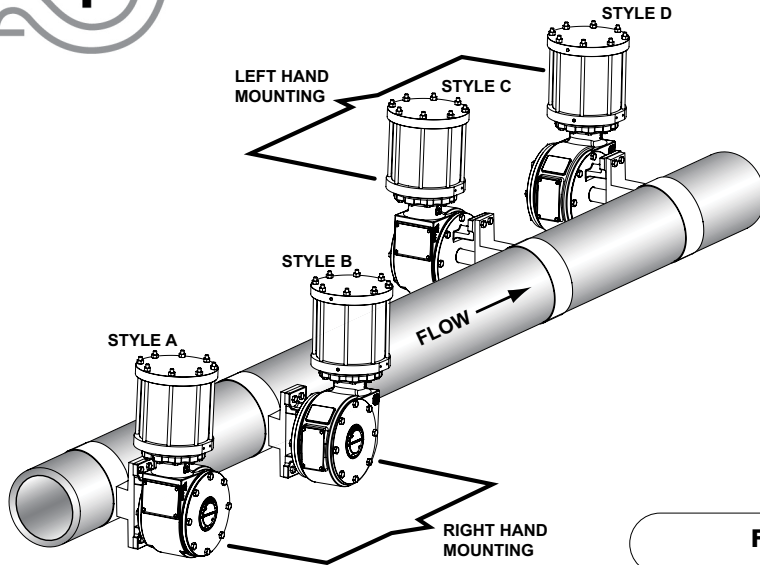

Figure 12 Changing Actuator Style



# Model DFRP Rotary Actuator

## Operation, Parts, and Instruction Manual



**Figure 13**  
DFRP Mounting Positions

**Figure 14** DFRP Operating Positions

### RIGHT HAND MOUNTING - DFRP WITH 590 CONTROL VALVE

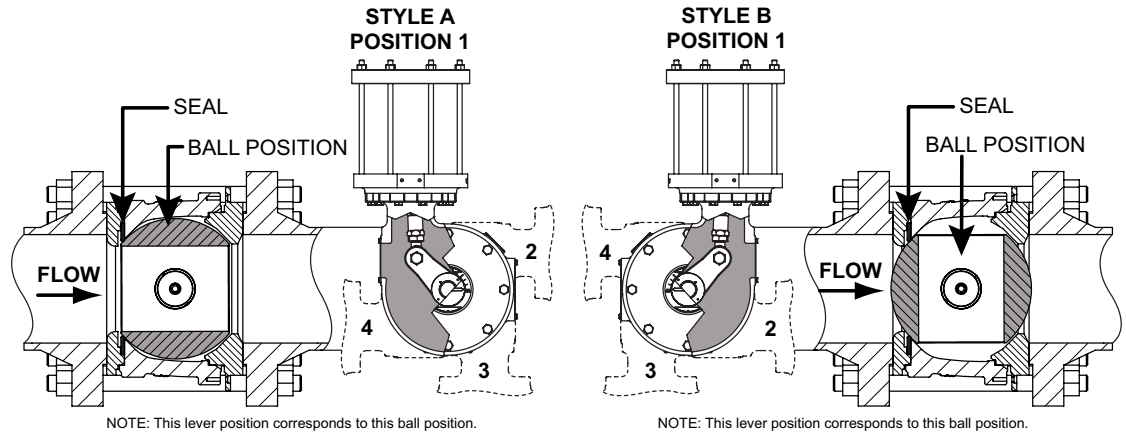

### LEFT HAND MOUNTING - DFRP WITH 590 CONTROL VALVE

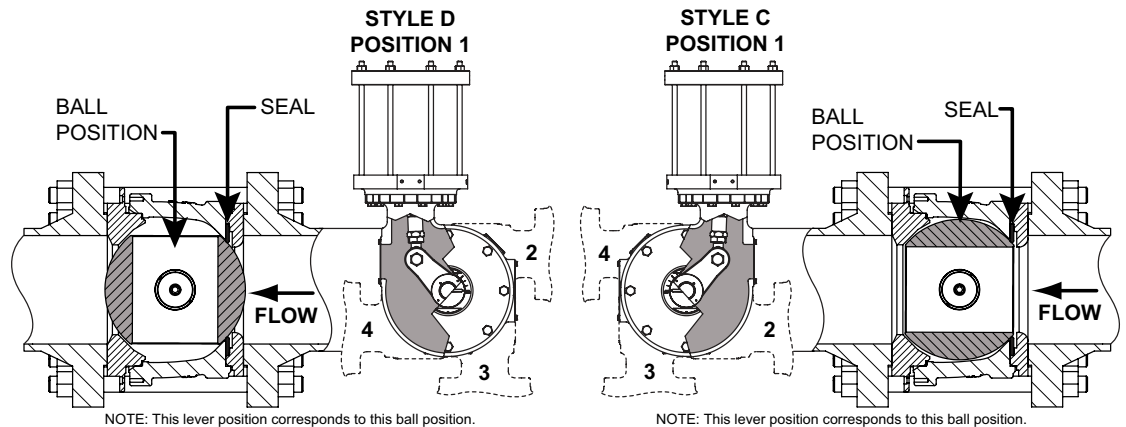

**NOTES:**

Position 1 is standard.  
Positions 2 - 4 are optional.

Forward Flow is into the face side of the ball sealing surface.

Reverse Flow is into the hub side of the ball.

# Model DFRP Rotary Actuator

## Operation, Parts, and Instruction Manual



**Table 1**

### DFRP Mounting Styles and Positions

Mounting	Action	Ball/Disc Rotation to Close	Valve Model		Ball/Disc Rotation to Close	Valve Model
			590	570, 571, 573		
Right-Hand	Push Down to Close	Counterclockwise	A	A	Clockwise	—
	Push Down to Open	Counterclockwise	B	B	Clockwise	—
Left-Hand	Push Down to Close	Counterclockwise	—	D	Clockwise	C
	Push Down to Open	Counterclockwise	—	C	Clockwise	D
Left-Hand (Optional)	Push Down to Close	Clockwise	—	C	—	—
	Push Down to Open	Clockwise	—	D	—	—

## ACTUATOR DISASSEMBLY

### Before You Begin:

- Read the General and Scope section of this manual (Page 2).
- Read Safety Caution (Page 2).
- Use safe work practices and lock out procedures.
- Disconnect supply lines (air or gas), electric power, or control signal to the actuator. Sudden movement of actuator can cause damage or injury, make sure actuator will not operate.
- Vent any pneumatic actuator loading pressure.
- Relieve process pressure and drain the process fluid from up and down stream of valve.
- Be aware of potentially hazardous process material that may be present in-line and in-valve. Isolate the valve from process pressure. Use a bypass or block valve if necessary, or completely shut off the process. Relieve internal valve pressure (refer to the appropriate valve instruction manual).

### Special Tools Required:

- Split ring pliers.
- Soft tip felt marker.
- Wrenches (See Table 4 for open-end wrenches required for turnbuckle adjustment). Size 112 requires a metal rod for removing the turnbuckle and hex nut, see above mentioned table for dimensions.

- 1 If the actuator has been removed from the valve and pipeline, secure the actuator assembly in place on a flat work surface that will support the weight.

- 2 Remove any positioners installed on the actuator.
- 3 Remove the cover plate cap screws (Key 47) and washers (Key 46).
- 4 Remove the cover plate/bushing assembly (Keys 38, 39, 40, 41, 42, 43, 44, and 45).
- 5 Inspect all parts for damage or wear, replace or repair parts as necessary. All soft parts such as seals and o-rings should be replaced.

### COVER PLATE DISASSEMBLY

- 1 Using the split ring pliers, remove the retaining ring (Key 43).
- 2 Remove the hub (Key 42) from the cover plate (Key 38).
- 3 If necessary, remove the machine screws (Key 45) and travel indicator (Key 44) from the hub (Key 42).
- 4 Inspect the bushing (Key 39). If the bushing needs to be replaced, remove the machine screws (Key 41) and remove the travel scale (Key 40). Once the travel scale has been removed, remove the bushing from the cover plate (Key 39).

### LEVER REMOVAL

- 1 Make note of the position of the lever (Key 32) and valve shaft (Key V), mark the position of each with a soft tip felt marker if necessary.



# Model DFRP Rotary Actuator

## Operation, Parts, and Instruction Manual

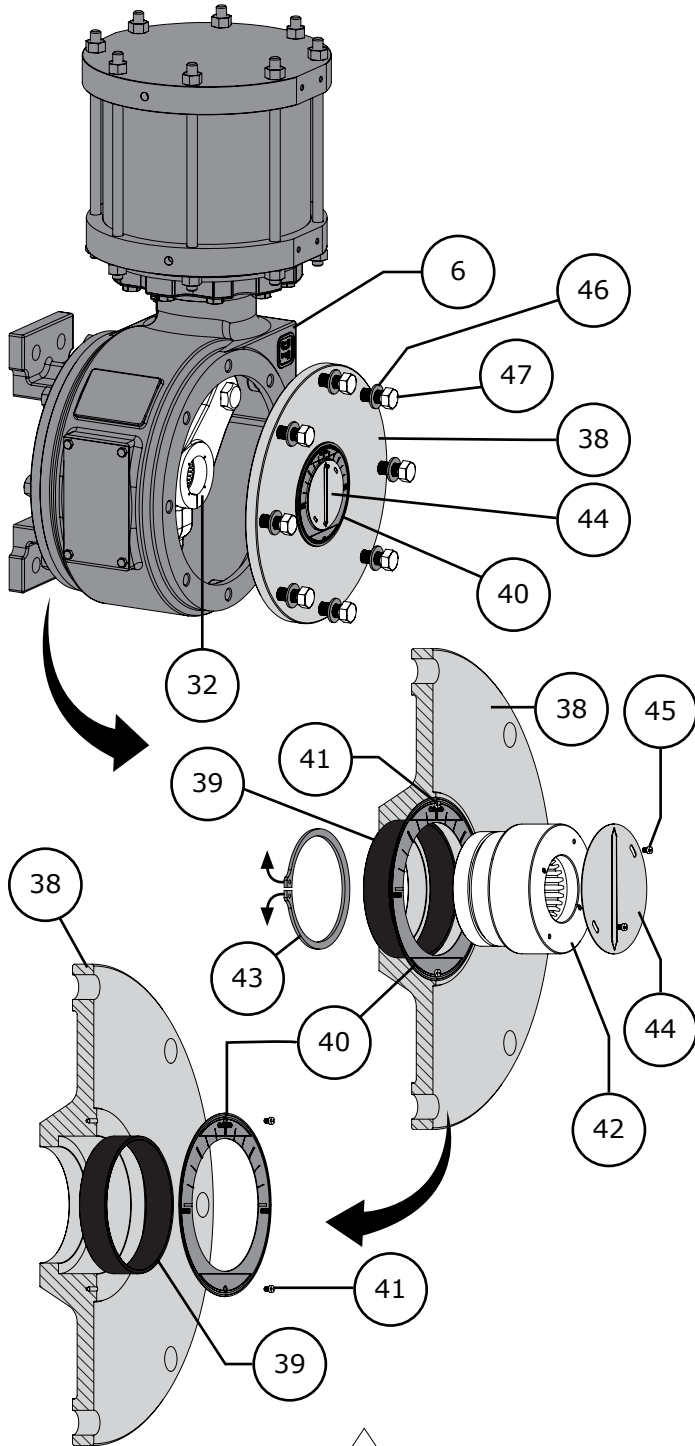

**Figure 15** Cover Plate Disassembly

### ACTUATOR DISASSEMBLY (Continued)

#### LEVER REMOVAL (Continued)

- 2 If needed, support the lever (Key 32) and remove the cap screw (Key 35), hex nut (Key 37), and washer (Key 36).  
**Note:** Only sizes 113 and 154 have a washer.

If the actuator is still mounted to the valve, loosen the lever clamp cap screw (Key 33). It may be necessary to tighten the lever adjustment set screw (Key 34) to spread the split portion of the lever (Key 32) to allow for easier removal. Refer to Figure 7. **DO NOT** use excessive force to drive the lever off of the valve shaft, excessive force could damage internal valve parts.

#### CYLINDER DISASSEMBLY

- 1 Refer to Figures 5 and 16, then remove the rod end bearing (Key 31), lower hex nut (Key 30), turnbuckle (Key 29), and left-hand threaded hex nut (Key 28) from the piston rod (Key 19).
- 2 Remove the lower hex nuts (Key 27) from the cylinder studs (Key 17). Remove the cylinder studs from the cylinder cap (Key 25) and then remove the upper hex nuts (Key 27).
- 3 Remove the cylinder cap (Key 25) and o-ring (Key 26) from the cylinder cap.
- 4 Remove the piston assembly (Keys 19, 20, 21, 22 or 23, and 24) from inside the cylinder (Key 18). Inspect the assembly and replace the o-ring (Key 24), if other parts need to be replaced or repaired, disassemble as follows:
  - A Keep the piston rod (Key 19) from twisting during disassembly with either a wrench on the flats or a wrench placed on two jam nuts. Remove the hex nut or cap screw (Key 22 or 23) from the top of the piston rod. **Note:** Actuator sizes 018 to 112 use a washer (Key 21) and a cap screw in place of the hex nut. Refer to Figures 17 and 23 for more detail.
  - B Remove the piston (Key 20) from the piston rod (Key 19). Replace or repair parts as necessary.
- 5 Remove the cylinder (Key 18). Refer to Figure 18.
- 6 Remove the o-ring (Key 15) from the cylinder base (Key 8).
- 7 Remove the travel stop (Key 16) if present, travel stop is not part of standard construction.
- 8 Remove the cap screws (Key 14) from the housing (Key 6).



# Model DFRP Rotary Actuator

## Operation, Parts, and Instruction Manual

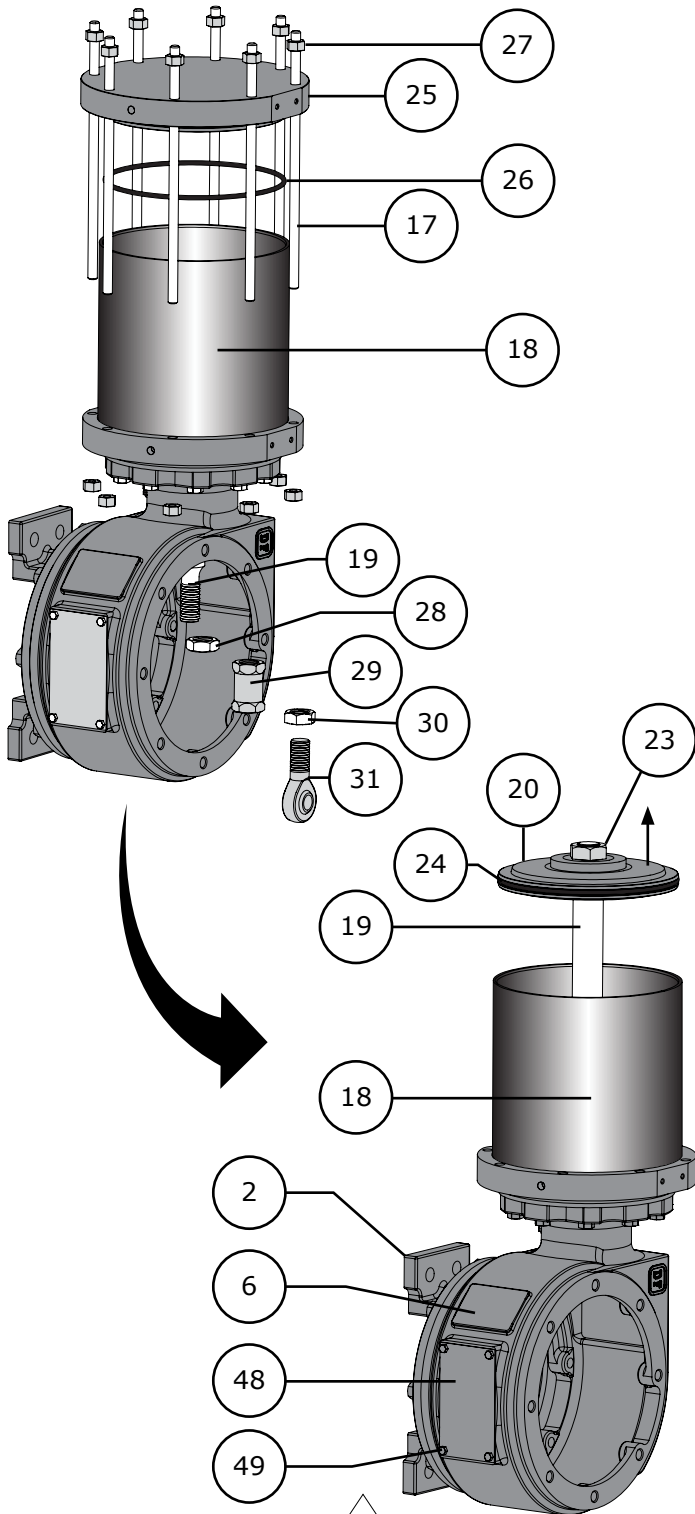

**Figure 16** Piston Rod Assembly Removal

### ACTUATOR DISASSEMBLY (Continued)

#### CYLINDER DISASSEMBLY (Continued)

- 9** Remove the cylinder base (Key 8) from the housing (Key 6). Use caution when removing the cylinder base as the sliding seal (Key 10) may stick to the cylinder base as it is being removed. Refer to Figure 18.
- 10** Remove the seal support (Key 13) and thrust washer (Key 12).
- 11** Remove the sliding seal (Key 10) and the o-ring (Key 11) from inside the sliding seal.
- 12** Remove the o-ring (Key 9) from the cylinder base (Key 8).
- 13** Inspect all parts for damage or wear, replace or repair parts as necessary. Pay special attention to any wear or damage inside o-ring grooves. All soft parts such as thrust washer and o-rings should be replaced.

#### YOKE REMOVAL/DISASSEMBLY

- 1** Support the actuator housing (Key 6) before removing the yoke (Key 2). To remove the yoke, remove the cap screws (Key 7). Refer to Figure 19.

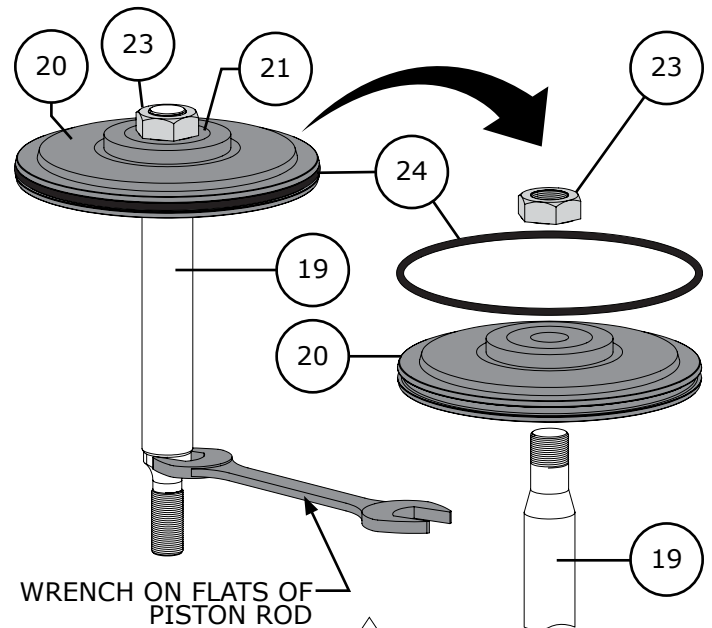
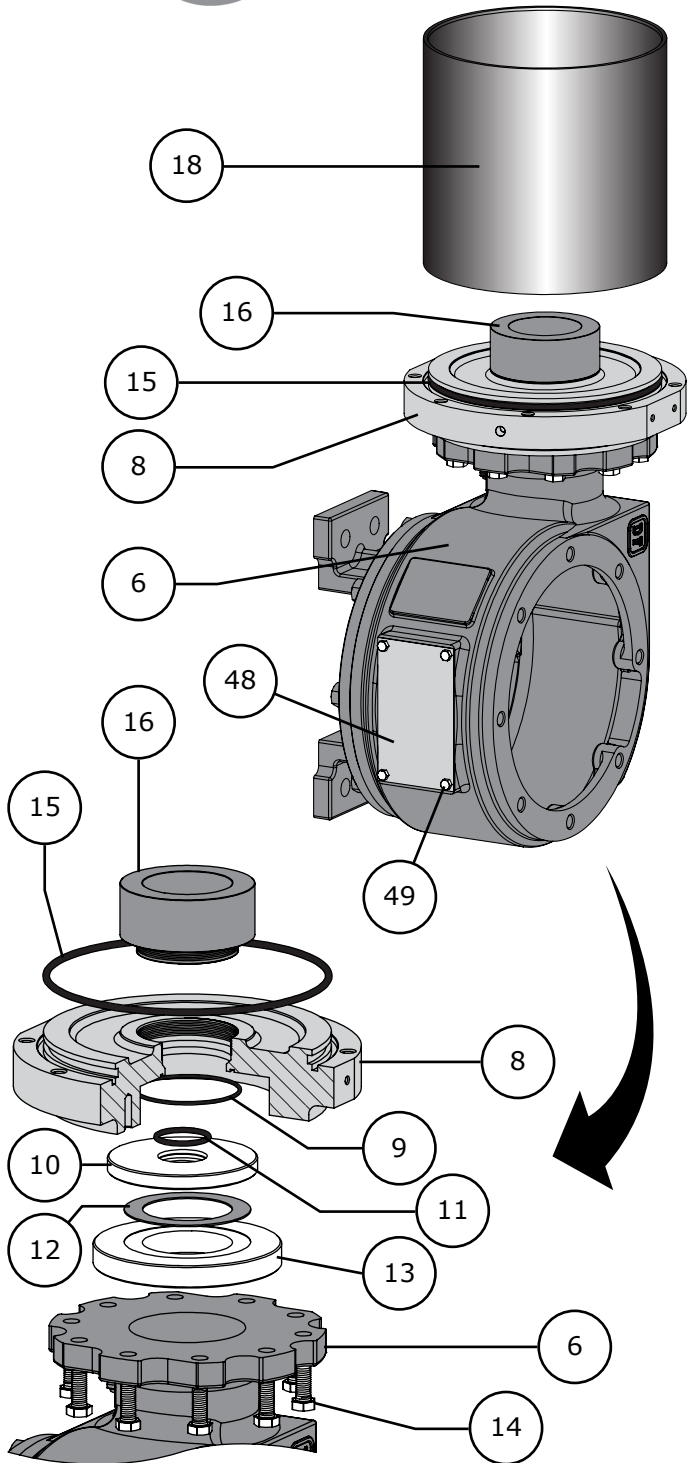

**Figure 17** Piston Rod Disassembly (Size 113 & 154)



# Model DFRP Rotary Actuator

## Operation, Parts, and Instruction Manual

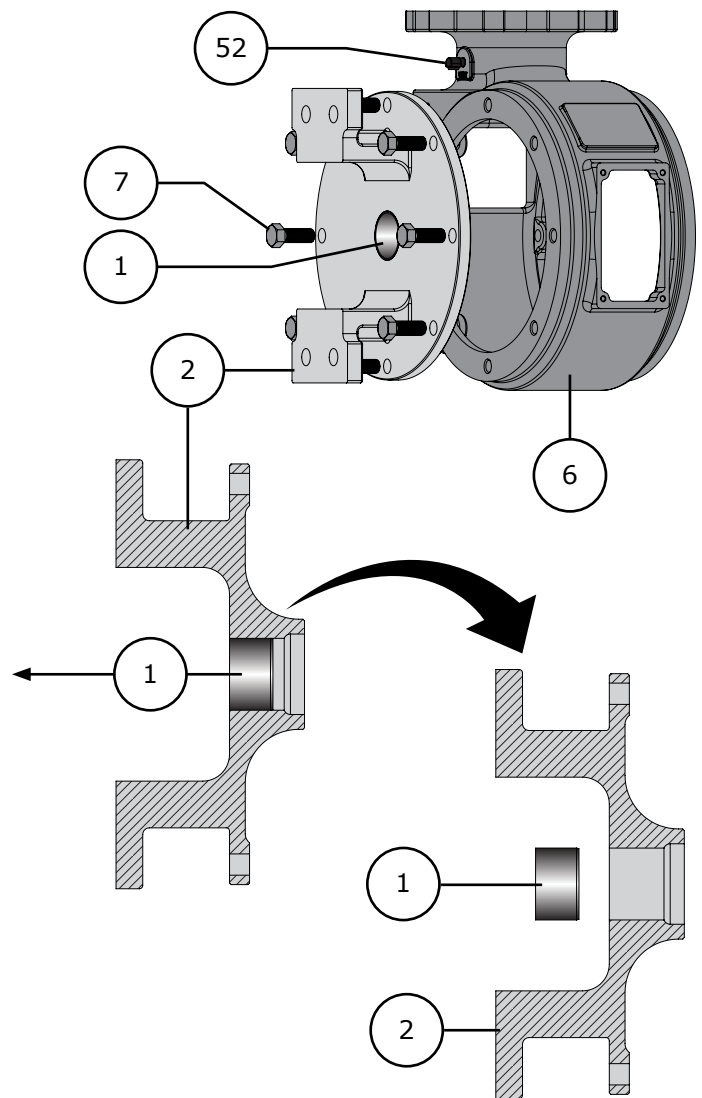

**Figure 18** Cylinder Base Removal

### ACTUATOR DISASSEMBLY (Continued)

#### YOKE REMOVAL/DISASSEMBLY (Continued)

- 2 Once removed, inspect the bushing (Key 1) inside the yoke (Key 2). If the bushing is worn or damaged it will need to be replaced.
- 3 Replace the bushing (Key 1) by carefully pressing it out of the yoke (Key 2). Refer to Figure 19.



**Figure 19** Yoke Removal and Disassembly

# Model DFRP Rotary Actuator

## Operation, Parts, and Instruction Manual



### ASSEMBLY

#### Before You Begin:

- The Assembly section of this manual assumes that the actuator has been completely disassembled prior to assembly.
- Read the General and Scope section of this manual (Page 2).
- Read Safety Caution (Page 2).
- Use safe work practices and lock out procedures.

#### Special Tools Required:

- Split ring pliers.
- Wrenches (See Table 4 for open-end wrenches required for turnbuckle adjustment). Size 112 requires a metal rod for removing the turnbuckle and hex nut, see above mentioned table for dimensions.

#### Lubricants Required:

- Anti-Seize Compound (Key A)
- Silicone-based O-Ring Compound (Key B)
- White Petroleum Grease (Key C)
- Refined Petroleum Oil (Key D)
- Liquid Thread Sealant (Key F)

**Note:** These assembly instructions assume that the control valve is still installed in the pipeline. If the control valve has been removed from the pipeline, make sure that the valve is placed securely on a flat work surface or clamping device that can support the combined weight of the control valve/actuator assembly.

#### BUSHING/YOKE ASSEMBLY

- 1 If the bushing (Key 1) was removed from the yoke (Key 2), press in a new bushing. The end of the bushing should be flush with the outside face of the yoke (see Figure 20).
- 2 Install the mounting yoke (Key 2) over the valve shaft (Key V) and secure it to the valve with the mounting bolts (Key 3) and lockwashers (Key 4) for Model 590 valves. Model 570 valves will also require a hex nut (Key 5). Tighten the cap screws to the torque values shown in Table 2.

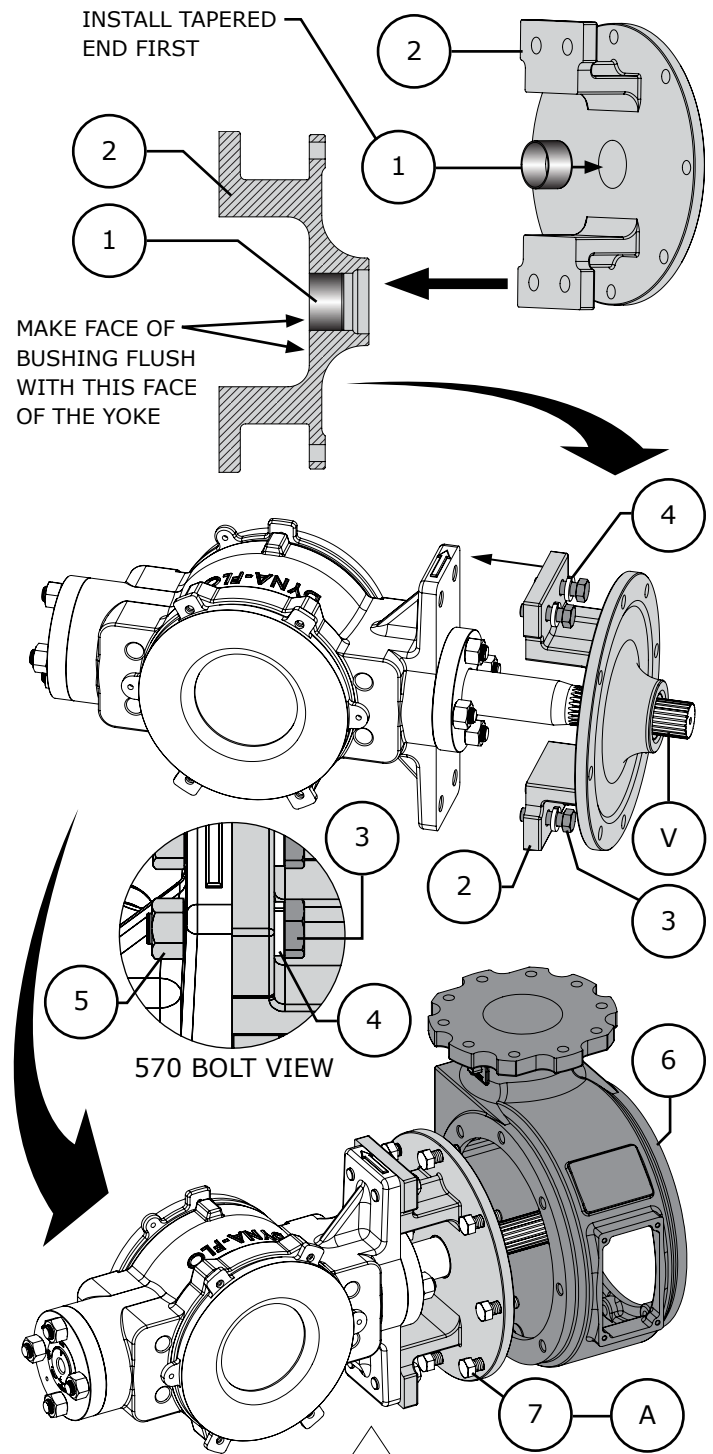

**Figure 20** Yoke / Housing / Valve Assembly



# Model DFRP Rotary Actuator

## Operation, Parts, and Instruction Manual

### ASSEMBLY (Continued)

#### BUSHING/YOKE ASSEMBLY (Continued)

- 3 Apply a small amount of anti-seize compound (Key A) to the threads of the cap screws (Key 7), then attach the actuator housing (Key 6) to the mounting yoke (Key 2) using the cap screws. Refer to Figure 13 and 14 to confirm desired actuator mounting orientation on the valve. Refer to Table 3 for cap screw (Key 7) torque specifications.

#### CYLINDER ASSEMBLY

- 1 Take the cylinder base (Key 8) and turn it upside down. Apply silicone-based o-ring compound (Key B) to the o-ring (Key 9) and install the o-ring into the cylinder base.
- 2 Apply silicone-based o-ring compound (Key B) to the o-ring (Key 11) and insert the o-ring into the o-ring groove of the sliding seal (Key 10). Refer to Figure 21.
- 3 Set the sliding seal (Key 10) into the cylinder base (Key 8).
- 4 Apply silicone-based o-ring compound (Key B) to both faces of the thrust washer (Key 12). Set the thrust washer into the groove of the seal support (Key 13), the o-ring compound will cause the thrust washer to stick in the groove of the seal support.
- 5 Set the seal support (Key 13) into the cylinder base (Key 8) so that the thrust washer (Key 12) sits on top of the sliding seal (Key 10). Refer to Figure 21.
- 6 Apply anti-seize compound (Key A) to the threads of the cap screws (Key 14) and while holding the cylinder base assembly (Keys 8, 9, 10, 11, 12, and 13) together install the assembly onto the actuator housing (Key 6). Refer to Figure 21 and Table 3 for cap screw (Key 14) torque specifications.
- 7 If a travel stop (Key 16) is to be used, apply anti-seize compound (Key A) to the threads of the travel stop and thread it into the cylinder base (Key 8).
- 8 Apply silicone-based o-ring compound (Key B) to the o-ring (Key 15) and install the o-ring into the groove of the cylinder base (Key 8).
- 9 Clean and then coat the inner wall of the cylinder (Key 18) with a thin layer of silicone-based o-ring compound (Key B) and install the cylinder onto the cylinder base (Key 8) so that the cylinder rests between the cylinder base and the o-ring (Key 15).

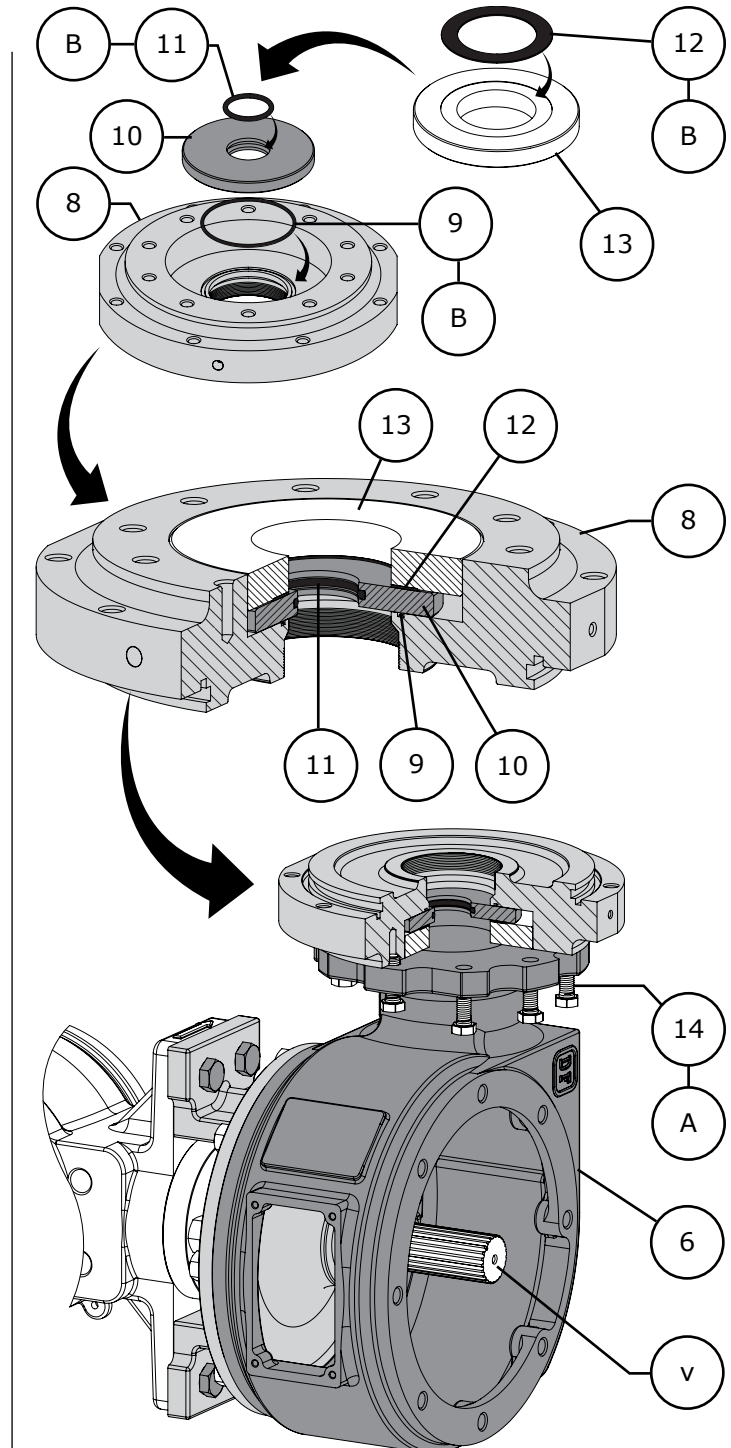

**Figure 21** Cylinder Base / Sliding Seal Assembly

# Model DFRP Rotary Actuator

## Operation, Parts, and Instruction Manual

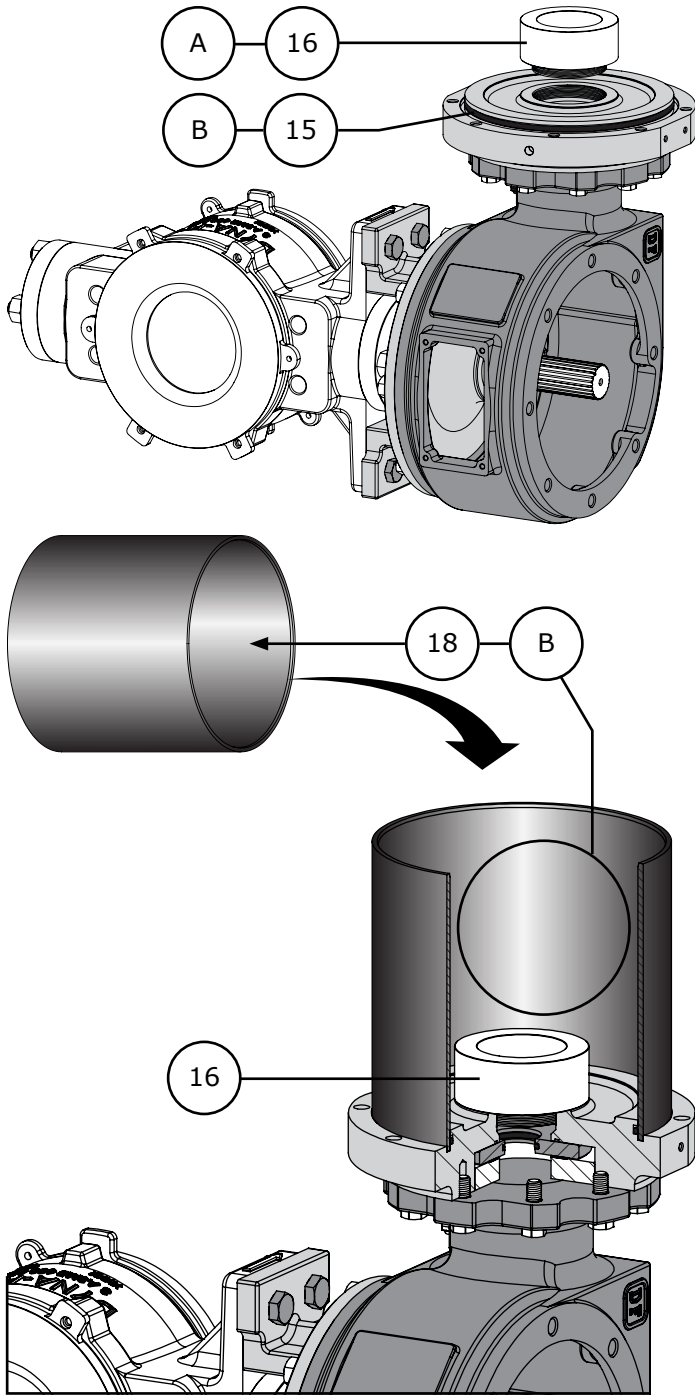

**Figure 22** Travel Stop and Cylinder Installation

### ASSEMBLY (Continued)

#### PISTON ASSEMBLY

- 1** Apply liquid thread sealant (Key F) to the tapered face of the piston rod (Key 19).
- 2** Apply anti-seize compound (Key A) to the threads of the piston rod (Key 19) or threads of the cap screw (Key 22) if used. Slide the piston rod through the bore of the piston (Key 20). Install the washer (Key 21) onto the piston, sizes 113 and 154 do not use a washer. Secure the assembly together with the hex nut (Key 23) or cap screw (Key 22). Refer to Figure 23.
- 3** Place a wrench onto the flats of the piston rod (Key 19) or use two nuts as jam nuts and tighten the hex nut (Key 23) or cap screw (Key 22) to the torque specification shown in Table 3. Refer to Figure 23.
- 4** Apply silicone-based o-ring compound (Key B) to the o-ring (Key 24) and install the o-ring into the groove on the piston ring (Key 20).
- 5** Slide the piston assembly (Keys 19, 20, 21, 22 or 23, and 24) through the open end of the cylinder (Key 18) so that the end of the piston rod (Key 19) slides through the sliding seal (Key 10) and into the actuator housing (Key 6). Refer to Figure 24.
- 6** Apply silicone-based o-ring compound (Key B) to the o-ring (Key 26) and install the o-ring into the groove on the cylinder cap (Key 25).
- 7** Place the cylinder cap (Key 25) over the cylinder (Key 18). Refer to Figure 24.
- 8** Apply anti-seize compound (Key A) to the exposed threads of the cylinder studs (Key 17). Thread the hex nuts (Key 27) onto one end of the cylinder studs.
- 9** Slide the cylinder studs (Key 17) through both the cylinder cap (Key 25) and the cylinder base (Key 8). The hex nuts (Key 27) should be resting against the cylinder cap. Refer to Figure 24.
- 10** Thread the remaining hex nuts (Key 27) onto the exposed thread of the cylinder studs (Key 17) that stick out through the cylinder base (Key 8).
- 11** Tighten the hex nuts (Key 27) to the torque specification shown in Table 3.







# Model DFRP Rotary Actuator

## Operation, Parts, and Instruction Manual



### ASSEMBLY (Continued)

#### LEVER INSTALLATION

- 1 Apply anti-seize compound (Key A) to the threads of the piston rod (Key 19).
- 2 Thread the left-hand threaded hex nut (Key 28) all the way onto the piston rod (Key 19).
- 3 Thread the turnbuckle (Key 29) onto the piston rod (Key 19) until the turnbuckle makes contact with the hex nut (Key 28). Refer to Figures 25 and 6 for turnbuckle examples.
- 4 Apply anti-seize compound (Key A) to the threads of the rod end bearing (Key 31). Thread the other hex nut (Key 30) completely onto the rod end bearing (Key 31).
- 5 Thread the rod end bearing (Key 31) into the turnbuckle (Key 29) until the hex nut (Key 30) makes contact with the turnbuckle. Refer to Figure 25 and 5.
- 6 Lubricate the teeth of the valve shaft spline with refined petroleum oil (Key D). Refer to Figure 25.
- 7 Loosen the lever clamp cap screw (Key 33) if not already loosened. It may be necessary to tighten the lever adjustment set screw (Key 34) to spread the split portion of the lever (Key 32) to allow for easier installation (set screw may not be included on all actuator sizes). Install the lever onto the valve shaft (Key V). **Refer to Figures 7, 8, and 25 and appropriate valve instruction manual for proper lever orientation or if marks were made during disassembly refer to those marks.**
- 8 Slide the lever (Key 32) so that the rod end bearing (Key 31) will be in alignment between the cap screw holes of the lever. Loosen the set screw (Key 34) and tighten the cap screw (Key 33) once in position.
- 9 Connect the lever (Key 32) to the rod end bearing (Key 31), rotate the lever or move the piston rod (Key 19) as necessary. Refer to Figure 25 and 9:

#### For actuator sizes 028, 079, and 112:

- A** Install the cap screw (Key 35) through the lever (Key 32) and rod end bearing (Key 31). **Note:** It may be necessary to adjust the turnbuckle (Key 29) in order to meet alignment.
- B** Thread the hex nut (Key 37) onto the cap screw (Key 35) and tighten to the torque value specified in Table 3.

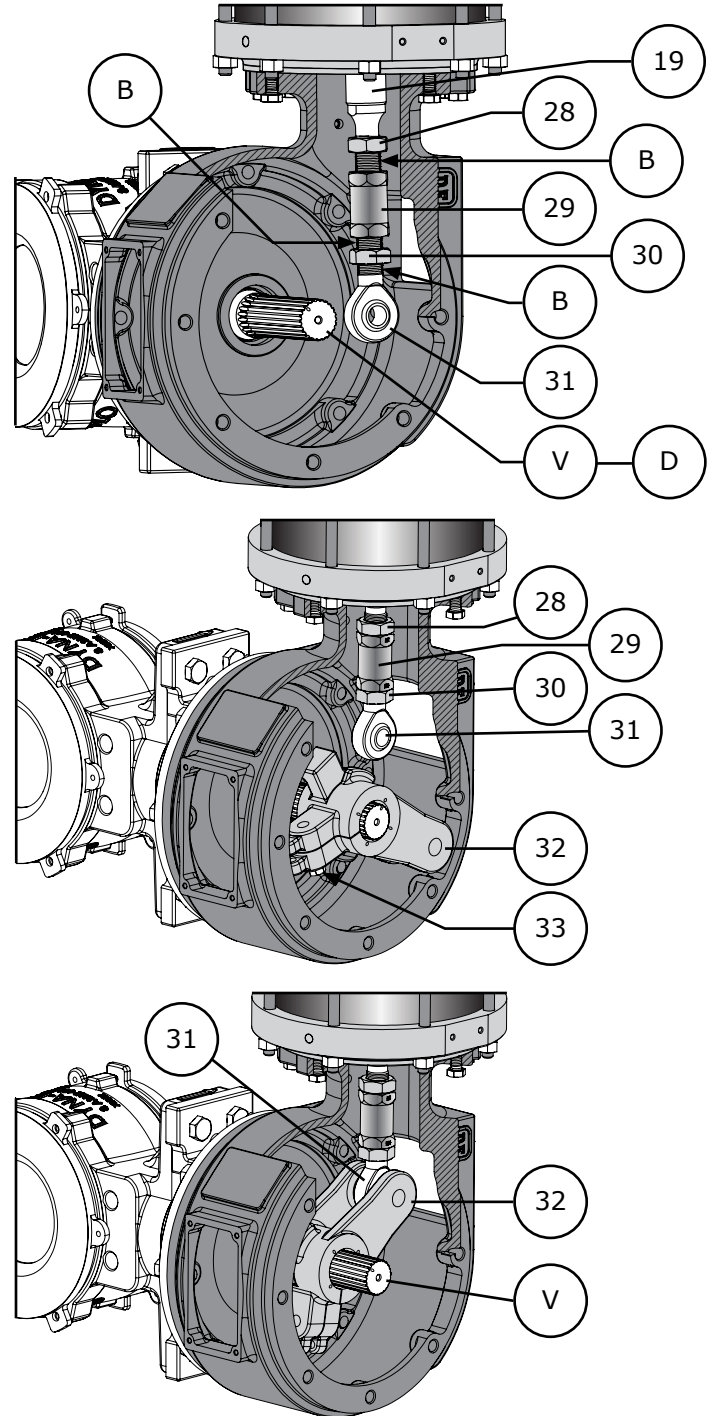

Figure 25 Lever Installation



# Model DFRP Rotary Actuator

## Operation, Parts, and Instruction Manual

### ASSEMBLY (Continued)

#### LEVER INSTALLATION (Continued)

##### 9 For actuator sizes 113 and 154:

- A** Install the cap screw (Key 35) through the lever (Key 32) and rod end bearing (Key 31). **Note:** It may be necessary to adjust the turnbuckle (Key 29) in order to meet alignment.
- B** Install the washer (Key 36) onto the cap screw (Key 35).
- C** Thread the hex nut (Key 37) onto the cap screw (Key 35) and tighten to the torque value specified in Table 3.

- 10** Refer to the Actuator Adjustment section (Page 8) for instructions on re-adjusting the turnbuckle assembly. Do not stroke the actuator while the cover plate (Key 38) is removed.

#### FOR ACTUATOR SIZES 028, 079, 112

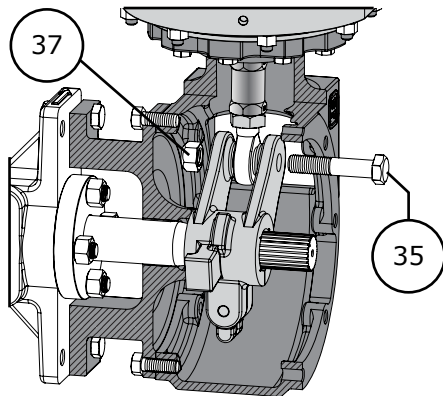

#### FOR ACTUATOR SIZES 113 & 154

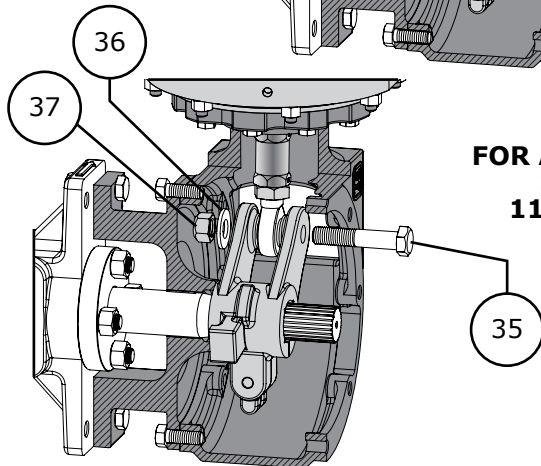

**Figure 26** Lever / Rod End Bearing Connection

#### COVER PLATE ASSEMBLY

- 1** If the bushing (Key 39) was removed, press a new bushing into the cover plate (Key 38).
- 2** Install the hub (Key 42) into the cover plate (Key 38). Using the split ring pliers, install the retainer ring (Key 43) onto the groove on the hub, this will secure the hub in the cover plate.
- 3** Install the travel scale (Key 40) using the machine screws (Key 41).
- 4** Install the travel indicator (Key 44) using the machine screws (Key 45). Rotate the hub (Key 42) so that once installed the arrows of the travel indicator are in alignment with the open or closed markers of the travel scale (Key 40) (the valve/actuator action will determine which position to place the travel indicator in).

#### COVER PLATE INSTALLATION

**Note:** If the actuator is equipped with a handwheel or positioner, refer to the separate instruction manual for those products, or contact Dyna-Flo Control Valves for more information.

- 1** Adjust the valve into the full open or fully closed position.
- 2** Slide the cover plate assembly (Keys 38, 39, 40, 41, 42, 43, 44, and 45) onto the valve stem (Key V) so that the valve stem slides through the teeth of the hub (Key 42). **Note:** Try to position the cover plate (Key 38) so that the holes in the cover plate align with those of the actuator housing (Key 6), it will also be necessary to position the cover plate appropriately so that the travel scale (Key 40) is in the desired orientation for valve position.
- 3** Apply anti-seize compound (Key A) to the threads of the cap screws (Key 47). Install the washers (Key 46) onto the cap screws and thread them through the cover plate (Key 38) and into the actuator housing (Key 6).
- 4** Secure the cover plate assembly in place by tightening the cap screws (Key 47) to the torque specification shown in Table 3.
- 5** Refer to the Actuator Adjustment section (Page 8) for instructions on re-adjusting the turnbuckle assembly.

# Model DFRP Rotary Actuator

## Operation, Parts, and Instruction Manual

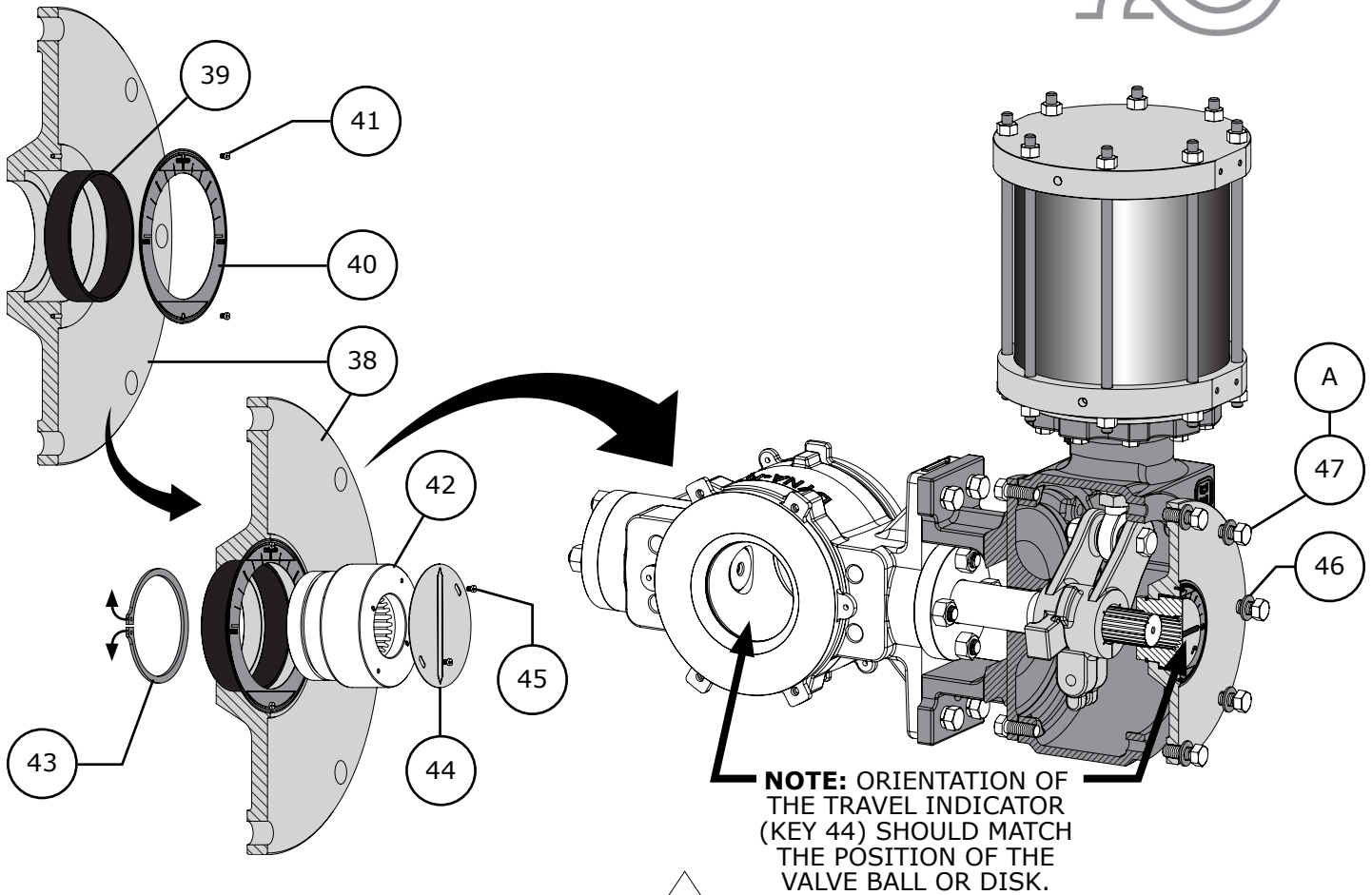
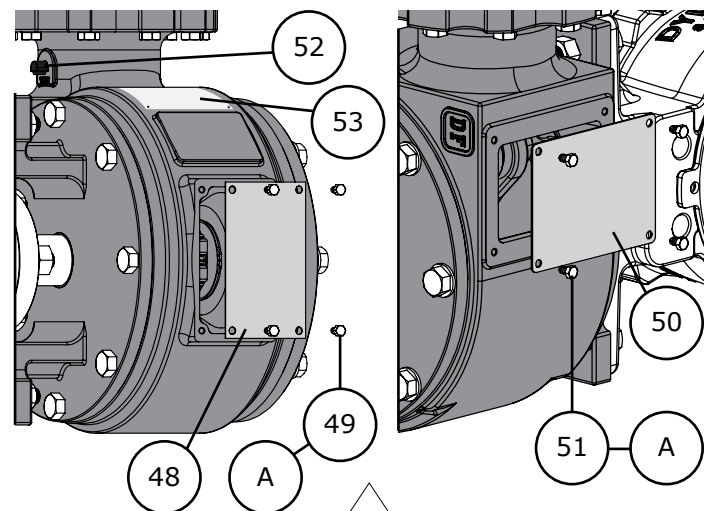

**Figure 27** Cover Plate Assembly

### ASSEMBLY (Continued)

#### PLATE AND VENT INSTALLATION

- 1 If the vent (Key 52) has not been installed into the actuator housing (Key 6), install it.
- 2 If the access plate (Key 50) and positioner plate (Key 48) have not been installed, do not install them until have the actuator adjustment have been performed.
- 3 Apply anti-seize compound (Key A) to the threads of the cap screws (Key 51) and use them to install the access plate (Key 50).
- 4 Apply anti-seize compound (Key A) to the threads of the cap screws (Key 49) and use them to install the positioner plate (Key 48).

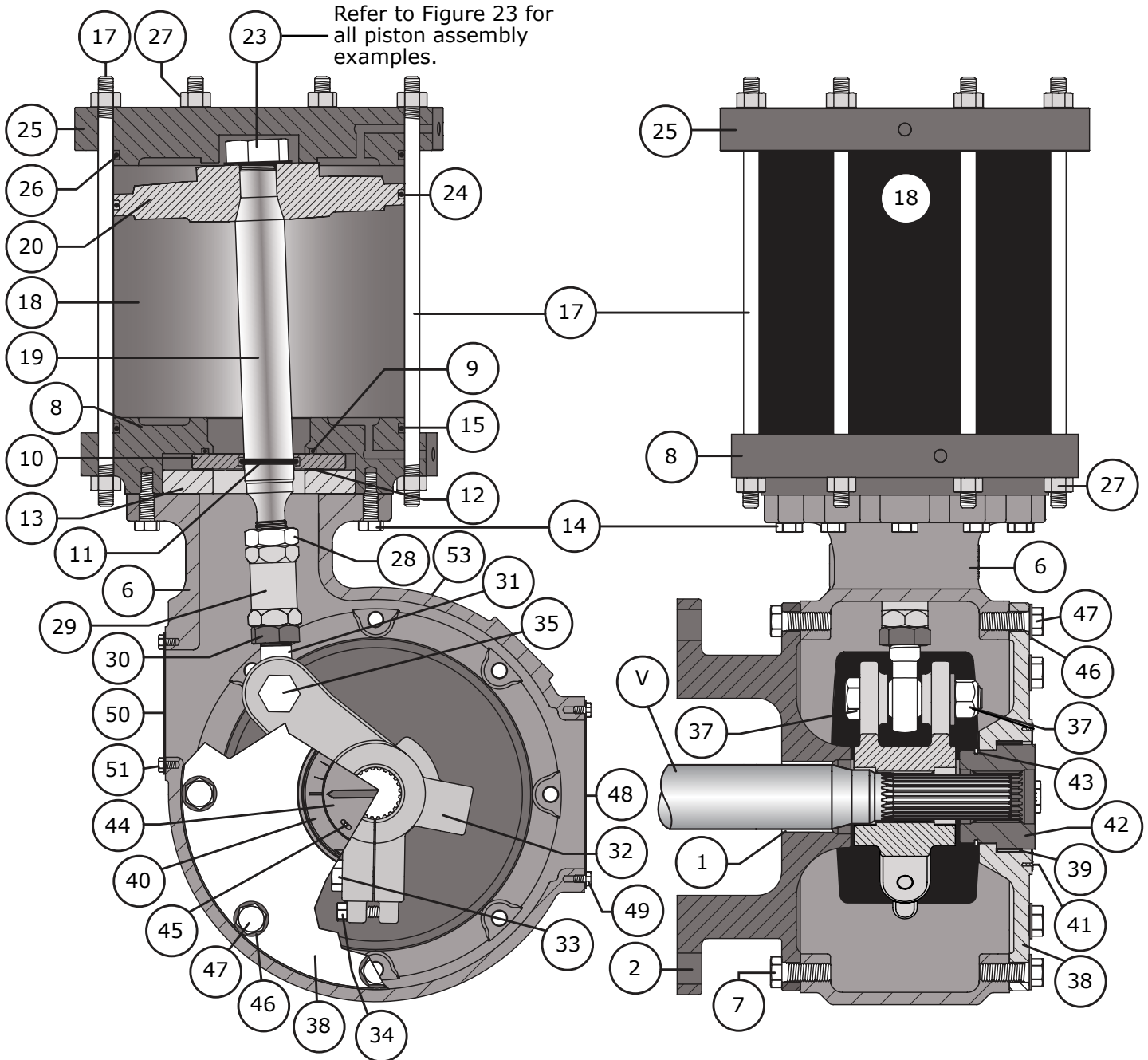

**Figure 28** Small Plate Installations



# Model DFRP Rotary Actuator

## Operation, Parts, and Instruction Manual



**Figure 29** DFRP Size 113 & 154 Actuator Cross Section

# Model DFRP Rotary Actuator

## Operation, Parts, and Instruction Manual



**Table 2**

### Torque Specifications for Valve Mounting Bolts (Key 3)

Valve Shaft Diameter	Mounting Bolts	
	lbf-ft	N•m
1/2 Inch to 1 Inch	65	80
1-1/4 Inch & 1-1/2 Inch	100	135
1-3/4 Inch & 2 Inch	135	183
2-1/2 Inch	290	390

**Table 3**

### DFRP Torque Specifications lbf-ft (N•m)

Key	Actuator Size		
	028 & 079	112	113 & 154
7	60 (81)	60 (81)	200 (271)
14	50 (68)	50 (68)	125 (169)
22	100 (136)	-	-
23	-	257 (248)	635 (861)
27	40 (54)	50 (68)	50 (68)
28	120 (163)	260 (253)	350 (475)
30	75 (102)	75 (102)	350 (475)
33	200 (271)	200 (271)	200 (271)
37	200 (271)	200 (271)	200 (271)
47	60 (81)	60 (81)	200 (271)
49 & 51	10 (14)	10 (14)	10 (14)

**Table 4**

### Open-End Wrench Size Requirements for Turnbuckle Assembly Adjustment

Actuator Size	Lower hex nut (Key 30)	Turnbuckle (Key 29)	Upper hex nut (Key 28)
028 & 079	1-1/8 Inch	1-5/16 Inch	1-5/16 Inch
112	1-1/8 Inch	3/8 Inch Diameter Rod*	3/8 Inch Diameter Rod*
113 & 154	1-7/8 Inch	1-7/8 Inch	1-7/8 Inch

\* **NOTE** - The size 112 actuator requires a 3/8" rod to adjust the turnbuckle and upper hex nut.





# Model DFRP Rotary Actuator

## Operation, Parts, and Instruction Manual

### Parts

Key	Description	Part Number
1	<b>Bushing</b> , Mounting Yoke, Bronze	Refer to Table 5
2	<b>Mounting Yoke &amp; Bushing Assembly</b> , Cast Iron & Bronze	Refer to Table 5
3	<b>Mounting Bolt</b> , Actuator / Valve, Steel Mounting bolts are included with the valve assembly.	
4	<b>Lockwasher</b> , Actuator / Valve, Steel lockwashers are included with the valve assembly.	
5	<b>Hex Nut</b> , Mounting Bolt, Steel Hex nuts are included with a 570 valve assembly.	
6	<b>Housing</b>	
	Size 028 (Cast Iron)	48A5246X01D
	Size 079 (Cast Iron)	48A5246X01D
	Size 112 (Cast Iron)	48A5246X01D
	Size 113 (Aluminum)	54A7814X02D
	Size 154 (Aluminum)	54A7814X02D
7	<b>Cap Screw</b> , Mounting Yoke, Steel	
	Size 028 (4 Required)	H5CZ12.112
	Size 079 (4 Required)	H5CZ12.112
	Size 112 (4 Required)	H5CZ12.112
	Size 113 (8 Required)	H5CZ34.200
	Size 154 (8 Required)	H5CZ34.200
8	<b>Cylinder Base</b> , Aluminum	
	Size 028	DFRP028071D
	Size 079	DFRP079071D
	Size 112	DFRP112071D
	Size 113	DFRP113071D
	Size 154	DFRP154071D
9	<b>O-Ring</b> , Cylinder Base, Nitrile	
	Size 028	DFRP028002D
	Size 079	DFRP028002D
	Size 112	13A0824X01D
	Size 113	1P23320699D
	Size 154	1P23320699D
10	<b>Sliding Seal</b> , Aluminum	
	Size 028	12A9468X02D
	Size 079	12A9468X02D
	Size 112	24A7869X02D
	Size 113	24A7811X01D
	Size 154	24A7811X01D
11	<b>O-Ring</b> , Sliding Seal, Nitrile	
	Size 028	DFRP028007D
	Size 079	DFRP028007D

Key	Description	Part Number
11	<b>O-Ring</b> , (Continued)	
	Size 112	1D34830699D
	Size 113	1H86270699D
	Size 154	1H86270699D
12	<b>Thrust Washer</b> , Sliding Seal, PTFE	
	Size 028	12A9662X01D
	Size 079	12A9662X01D
	Size 112	14A7871X01D
	Size 113	14A7829X01D
	Size 154	14A7829X01D
13	<b>Seal Support</b> , Cylinder, Aluminum	
	Size 028	12A9660X01D
	Size 079	12A9660X01D
	Size 112	14A7870X01D
	Size 113	14A7810X01D
	Size 154	14A7810X01D
14	<b>Cap Screw</b> , Cylinder Base, Zinc Plated Steel	
	Size 028 (4 Required)	H5CZ716.112
	Size 079 (4 Required)	H5CZ716.112
	Size 112 (4 Required)	H5CZ716.112
	Size 113 (10 Required)	H5CZ58.200
	Size 154 (10 Required)	H5CZ58.200
15	<b>O-Ring</b> , Cylinder Cap & Cylinder Base, Nitrile	
	Size 028 (2 Required)	DFRP028005D
	Size 079 (2 Required)	DFRP079005D
	Size 112 (3 Required)	DFRP113191D
	Size 113 (3 Required)	DFRP113191D
	Size 154 (3 Required)	DFRP154191D
16	<b>Travel Stop</b> (Not included in standard construction)	
	Size 028	
	Size 079	
	Size 112	
	Size 113	
	Size 154	
17	<b>Cylinder Studs</b> , S17400 DH1150	
	Size 028 (4 Required)	DFRP028081D
	Size 079 (8 Required)	DFRP079081D
	Size 112 (8 Required)	DFRP112081D
	Size 113 (8 Required)	DFRP154081D
	Size 154 (8 Required)	DFRP154081D
18	<b>Cylinder</b> , Fiberglass	
	Size 028	DFRP028161D
	Size 079	DFRP079161D



# Model DFRP Rotary Actuator

## Operation, Parts, and Instruction Manual



### Parts

Key	Description	Part Number
<b>18</b>	<b>Cylinder</b> (Continued)	
	Size 112	DFRP112161D
	Size 113	DFRP113161D
	Size 154	DFRP154161D
<b>19</b>	<b>Piston Rod</b> , S17400 H900	
	Size 028	DFRP028004D
	Size 079	22A9631X01D
	Size 112	24A7866X01D
	Size 113	24A7827X02D
	Size 154	24A7827X02D
<b>20</b>	<b>Piston</b> , Aluminum	
	Size 028	DFRP028003D
	Size 079	DFRP079111D
	Size 112	DFRP112111D
	Size 113	DFRP113111D
	Size 154	DFRP154111D
<b>21</b>	<b>Washer</b> , Piston Rod / Piston, S30400	
	Size 028	DFRP028006D
	Size 079	DFRP028006D
	Size 112	DFRP112006D
<b>22</b>	<b>Cap Screw</b> , Piston Rod, Zinc Plated Steel	
	Size 028	H5FZ58.200
	Size 079	H5FZ58.200
<b>23</b>	<b>Hex Nut</b> , Piston Rod, Zinc Plated Steel	
	Size 112	1C51172412D
	Size 113	NHJFZ112
	Size 154	NHJFZ112
<b>24</b>	<b>O-Ring</b> , Piston, Nitrile	
	Size 028	DFRP028191D
	Size 079	DFRP079191D
	Size 112	Refer to Key 15
	Size 113	Refer to Key 15
	Size 154	Refer to Key 15
<b>25</b>	<b>Cylinder Cap</b> , Aluminum	
	Size 028	DFRP028001D
	Size 079	DFRP079151D
	Size 112	DFRP113151D
	Size 113	DFRP113151D
	Size 154	DFRP154151D
<b>26</b>	<b>O-Ring</b> , Cylinder Cap & Cylinder Base, Nitrile	
	Refer to Key 15.	

Key	Description	Part Number
<b>27</b>	<b>Hex Nut</b> , Cylinder Stud, 2H Fluorokote	
	Size 028 (8 Required)	1A3772XFK1D
	Size 079 (16 Required)	1A3772XFK1D
	Size 112 (16 Required)	1A3760XFK1D
	Size 113 (16 Required)	1A3760XFK1D
	Size 154 (16 Required)	1A3760XFK1D
<b>28</b>	<b>Upper Hex Nut</b> , Turnbuckle, Zinc Plated Steel	
	Size 028	1R43892412D
	Size 079	1R43892412D
	Size 112 (Turnbuckle Lock)	26A0545X01D
	Size 113	10A6301X02D
	Size 154	10A6301X02D
<b>29</b>	<b>Turnbuckle</b> , Piston Rod, Zinc Plated Steel	
	Size 028	22A9630X01D
	Size 079	22A9630X01D
	Size 112	24A7868X01D
	Size 113	14A7826X01D
	Size 154	14A7826X01D
<b>30</b>	<b>Lower Hex Nut</b> , Turnbuckle, Zinc Plated Steel	
	Size 028	NHJFZ34
	Size 079	NHJFZ34
	Size 112	NHJFZ34
	Size 113	14A7825X01D
	Size 154	14A7825X01D
<b>31</b>	<b>Rod End Bearing</b> , Steel	
	Size 028	1R58769901D
	Size 079	1R58769901D
	Size 112	1R58769901D
	Size 113	14A7824X01D
	Size 154	14A7824X01D
<b>32</b>	<b>Lever</b> , Cast Iron	Refer to Table 5
<b>33</b>	<b>Cap Screw</b> , Lever Clamp, Zinc Plated Steel	
	Size 028	H5CZ34.134
	Size 079	H5CZ34.134
	Size 112	H5CZ34.134
	Size 113	H5CZ34.212
	Size 154	H5CZ34.212
<b>34</b>	<b>Set Screw</b> , Lever Adjustment, 18-8 SST	
	Size 113	SSC18.8.12.114
	Size 154	SSC18.8.12.114



# Model DFRP Rotary Actuator

## Operation, Parts, and Instruction Manual

### Parts

Key	Description	Part Number
<b>35</b>	<b>Cap Screw, Lever - Rod End Bearing, Zinc Plated Steel</b>	
	Size 028	H5CZ34.234
	Size 079	H5CZ34.234
	Size 112	H5CZ34.234
	Size 113	H5CZ100.500
	Size 154	H5CZ100.500
	<b>36</b>	<b>Washer, Lever - Rod End Bearing, Zinc Plated Steel</b>
Size 113		FWZN100
Size 154		FWZN100
<b>37</b>	<b>Lock Nut, Lever - Rod End Bearing, Zinc Plated Steel</b>	
	Size 028	NHJCZ34
	Size 079	NHJCZ34
	Size 112	NHJCZ34
	Size 113	14A7842X01D
<b>38</b>	<b>Cover Plate, Includes Bushing (Key 39),</b>	
	-Cast Iron & TFE/Graphite	
	Size 028	32A9532X01D
	Size 079	32A9532X01D
	Size 112	32A9532X01D
	-Aluminum & TFE/Graphite	
	Size 113	34A7805X01D
Size 154	34A7805X01D	
<b>39</b>	<b>Bushing, Cover Plate, TFE/Graphite</b>	
	Size 028	12A9374X01D
	Size 079	12A9374X01D
	Size 112	12A9374X01D
	Size 113	14A7815X01D
<b>40</b>	<b>Travel Scale, S30400</b>	
	Size 028	28A8492X01D
	Size 079	28A8492X01D
	Size 112	28A8492X01D
	Size 113	28A8497X01D
<b>41</b>	<b>Machine Screw, Travel Scale, Zinc Plated Steel</b>	
	Size 028 (2 Required)	1A8664X00AD
	Size 079 (2 Required)	1A8664X00AD
	Size 112 (2 Required)	1A8664X00AD
	Size 113 (2 Required)	1A8664X00AD
<b>42</b>	<b>Hub</b>	Refer to Table 5

Key	Description	Part Number
<b>43</b>	<b>Retainer Ring, Hub, Carbon Steel</b>	
	Size 028	12A9455X01D
	Size 079	12A9455X01D
	Size 112	12A9455X01D
	Size 113	14A7816X01D
	Size 154	14A7816X01D
<b>44</b>	<b>Travel Indicator, S30400</b>	
	Size 028	28A8495X01D
	Size 079	28A8495X01D
	Size 112	28A8495X01D
	Size 113	28A8498X01D
<b>45</b>	<b>Machine Screw, Travel Indicator, Zinc Plated Steel</b>	
	Size 028 (2 Required)	1A8664X00AD
	Size 079 (2 Required)	1A8664X00AD
	Size 112 (2 Required)	1A8664X00AD
	Size 113 (2 Required)	1A8664X00AD
<b>46</b>	<b>Washer, Cover Plate, Zinc Plated Steel</b>	
	Size 028 (4 Required)	FWZ12
	Size 079 (4 Required)	FWZ12
	Size 112 (4 Required)	FWZ12
	Size 113 (8 Required)	FWZN34
<b>47</b>	<b>Cap Screw, Cover Plate, Zinc Plated Steel</b>	
	Size 028 (4 Required)	H5CZ12.114
	Size 079 (4 Required)	H5CZ12.114
	Size 112 (4 Required)	H5CZ12.114
	Size 113 (8 Required)	H5CZ34.200
<b>48</b>	<b>Positioner Plate, Steel</b>	
	Size 028	22A9359X01D
	Size 079	22A9359X01D
	Size 112	22A9359X01D
	Size 113	22A9359x01D
<b>49</b>	<b>Cap Screws, Positioner Plate, Zinc Plated Steel</b>	
	Size 028 (4 Required)	1C27522405D
	Size 079 (4 Required)	1C27522405D
	Size 112 (4 Required)	1C27522405D
	Size 113 (4 Required)	1C27522405D
	Size 154 (4 Required)	1C27522405D

# Model DFRP Rotary Actuator

## Operation, Parts, and Instruction Manual



### Parts

Key	Description	Part Number
<b>50</b>	<b>Access Plate, Steel</b>	
	Size 028	12A9638X01D
	Size 079	12A9638X01D
	Size 112	12A9638X01D
	Size 113	14A7828X01D
	Size 154	14A7828X01D
<b>51</b>	<b>Cap Screw, Access Plate, Zinc Plated Steel</b>	
	Size 028 (4 Required)	1A33212898D
	Size 079 (4 Required)	1A33212898D
	Size 112 (4 Required)	1A33212898D
	Size 113 (4 Required)	1C27522405D
	Size 154 (4 Required)	1C27522405D
<b>52</b>	<b>Vent, Plastic/Aluminum</b>	Y602-12D
<b>53</b>	<b>Nameplate, Aluminum</b>	NAMEXSRACTD
	Size 113 (8 Required)	FWZN34
	Size 154 (8 Required)	FWZN34

### Parts Ordering

Whenever corresponding with Dyna-Flo about a DFRP actuator, refer to the nameplate (Key 53) for the serial number of the unit. Please order by the complete part number (as given in the following parts list) of each part required.



# Model DFRP Rotary Actuator

## Operation, Parts, and Instruction Manual

Table 5

<b>DFRP 028 Parts Table</b>						
SHAFT SIZE	MOUNTING YOKE	YOKE/BUSHING ASSEMBLY (Key 2)	BUSHING (Key 1)	LEVER (Key 32)	HUB (Key 42)	HUB MATERIAL
3/4"	12A9799156A	12A9799X0DD	DFRBSHX750D	32A9573X01D	22A9499X01D	S41600
7/8"	12A9799156A	12A9799X0FD	DFRBSHX875D	32A9574X01D	22A9420X01D	S41600/Aluminum
1"	12A9799156A	12A9799X0HD	DFRBSHX100D	32A9574X01D	22A9420X01D	S41600/Aluminum
1-1/4"	12A9799220A	12A9799X0JD	DFRBSHX125D	32A9575X01D	22A9500X01D	S41600/Aluminum
1-1/2"	12A9799600A	12A9799X0KD	DFRBSHX150D	32A9576X01D	22A9501X01D	S41600/Aluminum
1-3/4"	12A9799112A	12A9799X0LD	DFRPB411X1D	32A9679X01D	24A6358X01D	S41600
2"	12A9799112A	12A9799X0MD	DFRPB412X1D	32A9679X01D	24A6358X01D	S41600

<b>DFRP 079 Parts Table</b>						
SHAFT SIZE	MOUNTING YOKE	YOKE/BUSHING ASSEMBLY (Key 2)	BUSHING (Key 1)	LEVER (Key 32)	HUB (Key 42)	HUB MATERIAL
3/4"	12A9799156A	12A9799X0DD	DFRBSHX750D	32A9573X01D	22A9499X01D	S41600
7/8"	12A9799156A	12A9799X0FD	DFRBSHX875D	32A9574X01D	22A9420X01D	S41600/Aluminum
1"	12A9799156A	12A9799X0HD	DFRBSHX100D	32A9574X01D	22A9420X01D	S41600/Aluminum
1-1/4"	12A9799220A	12A9799X0JD	DFRBSHX125D	32A9575X01D	22A9500X01D	S41600/Aluminum
1-1/2"	12A9799600A	12A9799X0KD	DFRBSHX150D	32A9576X01D	22A9501X01D	S41600/Aluminum
1-3/4"	12A9799112A	12A9799X0LD	DFRPB411X1D	32A9679X01D	24A6358X01D	S41600
2"	12A9799112A	12A9799X0MD	DFRPB412X1D	32A9679X01D	24A6358X01D	S41600

<b>DFRP 112 Parts Table</b>						
SHAFT SIZE	MOUNTING YOKE	YOKE/BUSHING ASSEMBLY (Key 2)	BUSHING (Key 1)	LEVER (Key 32)	HUB (Key 42)	HUB MATERIAL
3/4"	12A9799156A	12A9799X0DD	DFRBSHX750D	32A9573X01D	22A9499X01D	S41600
7/8"	12A9799156A	12A9799X0FD	DFRBSHX875D	32A9574X01D	22A9420X01D	S41600/Aluminum
1"	12A9799156A	12A9799X0HD	DFRBSHX100D	32A9574X01D	22A9420X01D	S41600/Aluminum
1-1/4"	12A9799220A	12A9799X0JD	DFRBSHX125D	32A9575X01D	22A9500X01D	S41600/Aluminum
1-1/2"	12A9799600A	12A9799X0KD	DFRBSHX150D	32A9576X01D	22A9501X01D	S41600/Aluminum
1-3/4"	12A9799112A	12A9799X0LD	DFRPB411X1D	32A9679X01D	24A6358X01D	S41600
2"	12A9799112A	12A9799X0MD	DFRPB412X1D	32A9679X01D	24A6358X01D	S41600

<b>DFRP 113 Parts Table</b>						
SHAFT SIZE	MOUNTING YOKE	YOKE/BUSHING ASSEMBLY (Key 2)	BUSHING (Key 1)	LEVER (Key 32)	HUB (Key 42)	HUB MATERIAL
1-3/4" SHAFT	12A9799113A	12A9799X0ND	DFRP113091D	34A7823X01D	24A7837X01D	S41600
2" SHAFT	12A9799113A	12A9799X0PD	DFRP113101D	34A7823X012	24A7837X012	S41600
2-1/2" SHAFT	12A9799113A	12A9799X0RD	DFRP154091D	34A7801X01D	24A7806X01D	S41600

# Model DFRP Rotary Actuator

## Operation, Parts, and Instruction Manual



**Table 5** (Continued)

**DFRP 154 Parts Table**

SHAFT SIZE	MOUNTING YOKE	YOKE/BUSHING ASSEMBLY (Key 2)	BUSHING (Key 1)	LEVER (Key 32)	HUB (Key 42)	HUB MATERIAL
1-3/4" SHAFT	12A9799113A	12A9799X0ND	DFRP113091D	34A7823X01D	24A7837X01D	S41600
2" SHAFT	12A9799113A	12A9799X0PD	DFRP113101D	34A7823X01D	24A7837X01D	S41600
2-1/2" SHAFT	12A9799113A	12A9799X0RD	DFRP154091D	34A7801X01D	24A7806X01D	S41600

### ***Our Commitment to Quality***

Dyna-Flo is committed to continuous improvement. While all efforts have been made to ensure the accuracy of the content in this document, modifications or improvements to the information, specifications, and designs may occur at any time without notice. This document was published for informational purposes only, and does not express or imply suitability, a warranty, or guarantee regarding the products or services described herein or their use or applicability.

Neither Dyna-Flo Control Valve Services Ltd., nor any of their affiliated entities assumes responsibility for the selection, use and maintenance of any product. Responsibility for selection, use and maintenance of any product remains with the purchaser and end-user.



# Model DFRP Rotary Actuator

## MODEL NUMBERING SYSTEM

**SAMPLE PART NUMBER: DFRP-112-06-RA1-N**

ACTUATOR						112
028	SIZE 028	079	SIZE 079	112	SIZE 112	
154	SIZE 154					
CYLINDER OPTIONS						-
-	STANDARD					
SHAFT CONNECTION SIZE						06
04	1/2 INCH	05	5/8 INCH	06	3/4 INCH	
08	1 INCH	10	1-1/4 INCH	12	1-1/2 INCH	
16	2 INCH	17	2-1/8 INCH	20	2-1/2 INCH	
PAINT						-
-	DFPS-01 (STANDARD)	2	DFPS-02 (SEVERE SERVICE)			
3	DFPS-03 (HIGH TEMPERATURE)					
MOUNTING						RA1
R	RIGHT HAND MOUNT - SEE FIGURES 13 & 14			L	LEFT HAND MOUNT - SEE FIGURES 13 & 14	
A	STYLE A   B   C   D - SEE FIGURES 13 & 14					
1	POSITION 1   2   3   4 - SEE FIGURES 13 & 14 (STANDARD POSITION IS RIGHT HAND POSITION 1)					
N	NOT APPLICABLE					
OPTIONS						-
-	NONE					
HANDWHEELS / ADJUSTABLE STOPS						N
N	NONE					

**DFRP -** \_\_\_\_\_